

**PowerBoss®**  
The Power of Clean

# PHOENIX-35 33" WALK BEHIND SCRUBBER



PowerBoss, Inc.  
A Member of The Hako Group

### **For Safety When Servicing or Maintaining Machine**

- Stop on level surface.
- Disconnect the power to the machine by pulling the red Battery Connector located under the recovery tank near the batteries.
- Avoid moving parts. Do not wear loose jackets, shirts, or sleeves when working on machine.
- Avoid contact with battery acid. Battery acid can cause burns. When working on or around batteries, wear protective clothing and safety glasses. Remove metal jewelry. Do not lay tools or metal objects on top of batteries.
- Do not clean machine with a pressure washer.
- Authorized personnel must perform repairs and maintenance. Use Minuteman supplied replacement parts.

<b>Assembly Group</b>	<b>Description</b>	<b>Page</b>
<b>99706218BT10</b>	<b>Chassis Assembly I</b>	<b>1</b>
	Lift Pedal Subassembly	2
	Brush Pressure Adjustment Subassembly	3
<b>99706218BT20</b>	<b>Chassis Assembly II</b>	<b>4</b>
	Traction Drive Motor Subassembly	5
<b>99706218BT30</b>	<b>Chassis Assembly III</b>	<b>6</b>
	Water Supply Subassembly I	7
	Water Supply Subassembly II	8
	Squeegee Connection Subassembly I	9
	Squeegee Connection Subassembly II	10
<b>99706218BT40</b>	<b>Battery Tray Assembly</b>	<b>11</b>
<b>99706218BT50</b>	<b>Solution Tank Assembly</b>	<b>12</b>
	Recovery Tank Drain Hose Subassembly	13
<b>99706218BT60</b>	<b>Recovery Tank Assembly</b>	<b>14</b>
<b>99706218BT70</b>	<b>Vacuum Motor Assembly</b>	<b>15</b>
<b>99706218BT80</b>	<b>Squeegee Lift Handle Assembly</b>	<b>16</b>
<b>99706218BT90</b>	<b>Squeegee Lock Assembly</b>	<b>17</b>
<b>99706218BT100</b>	<b>Squeegee Assembly I</b>	<b>18</b>
<b>99706218BT110</b>	<b>Squeegee Assembly II</b>	<b>19</b>
<b>99706218BT120</b>	<b>Control Panel Assembly</b>	<b>20</b>
	Console Subassembly	21
<b>99706218BT130</b>	<b>Electrical Assembly I</b>	<b>22</b>
	Retainer Subassembly	23
<b>99706218BT140</b>	<b>Electrical Assembly II</b>	<b>24</b>
<b>99706218BT150</b>	<b>Battery Charger Assembly</b>	<b>25</b>
<b>99706218BT160</b>	<b>Machine Labels</b>	<b>26</b>
<b>99706218BT170</b>	<b>Disc Scrub Deck Assembly I</b>	<b>27</b>
<b>99706218BT180</b>	<b>Disc Scrub Deck Assembly II</b>	<b>28</b>
<b>99706218BT190</b>	<b>Disc Scrub Deck Assembly III</b>	<b>29</b>

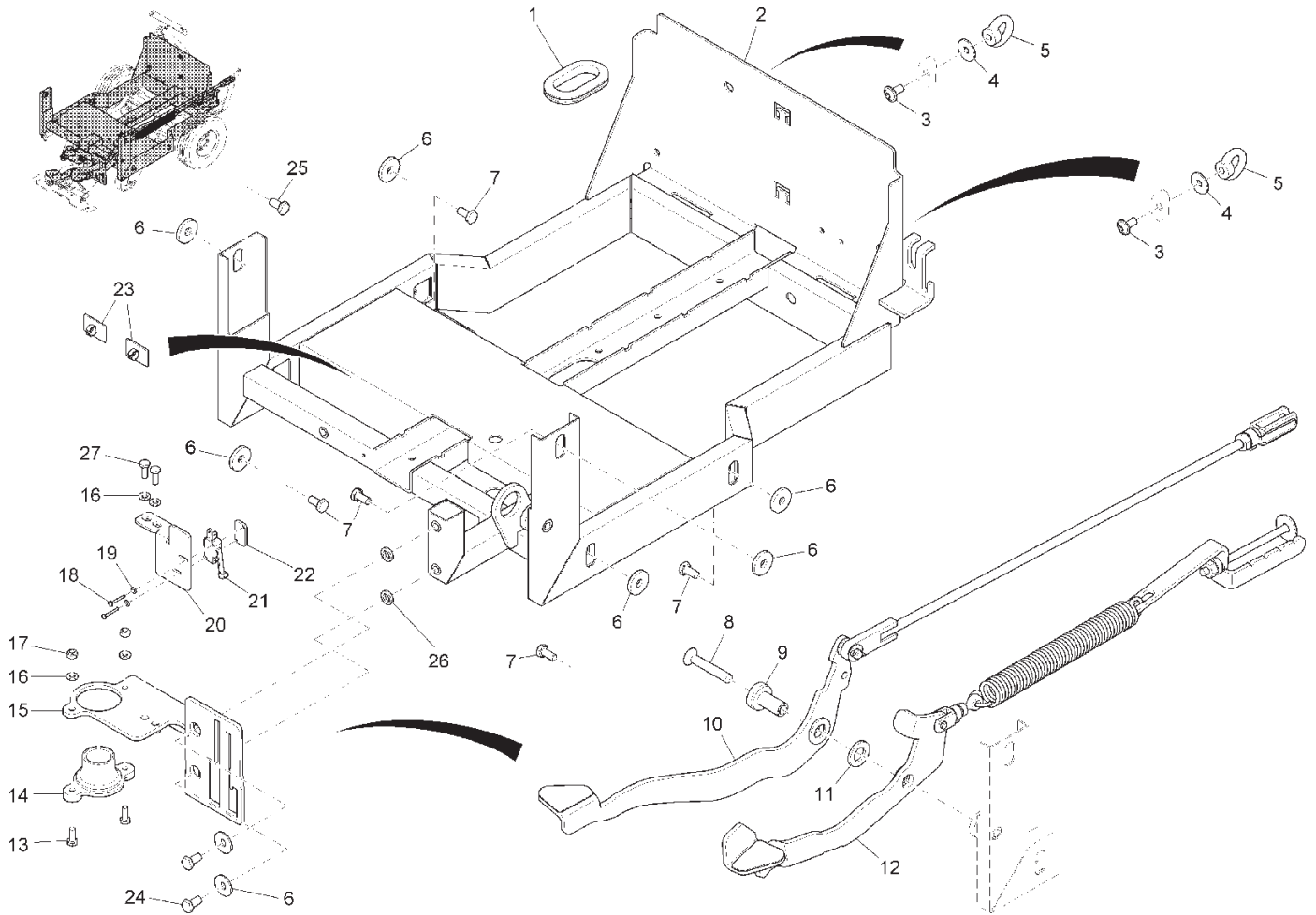

**Bill of Material - 99706218BT10**

Item	Spare part number	Mat. No.	Qty.	Description
1	01078440	90513367	1	Grommet
2	03007640	96116405	1	Chassis
3	01006820	11177128	2	Lens flange screw
4	00042900	12332029	4	Washer
5	01078450	12160024	2	Nut
6	00047990	12515086	10	Disk wheel
7	00053080	11038197	8	Hexagon screw
8	01078140	11225620	1	Countersunk screw
9	01077800	90509522	1	Bushing
10	99706218BT10-1		1	Lifting pedal
11	00053790	12310082	1	Washer
12	99706218BT10-2		1	Brush pression adjustment
13	00053020	11038098	2	Hexagon screw
14	01077780	90508391	1	Bushing
15	01079680	96117387	1	Sheet metal
16	00053730	12310033	4	Washer
17	00051520	12040044	2	Hexagon nut
18	00022180	11039088	2	Hex.bolt
19	00553740	12310132	2	Washer
20	01170010	90528787	1	Retainer
21	00975510	90306002	1	Micro switch
22	01074840	90471483	1	Thread base plate
23	01143190	17526070	2	Cable clip
24	00053100	11038247	2	Hexagon screw
25	00553690	11038635	1	Hex.bolt
26	01079670	90525692	2	Spacer sleeve
27	00053010	11038072	2	Hex.bolt

**Chassis Assembly I**  
Lift Pedal Subassembly

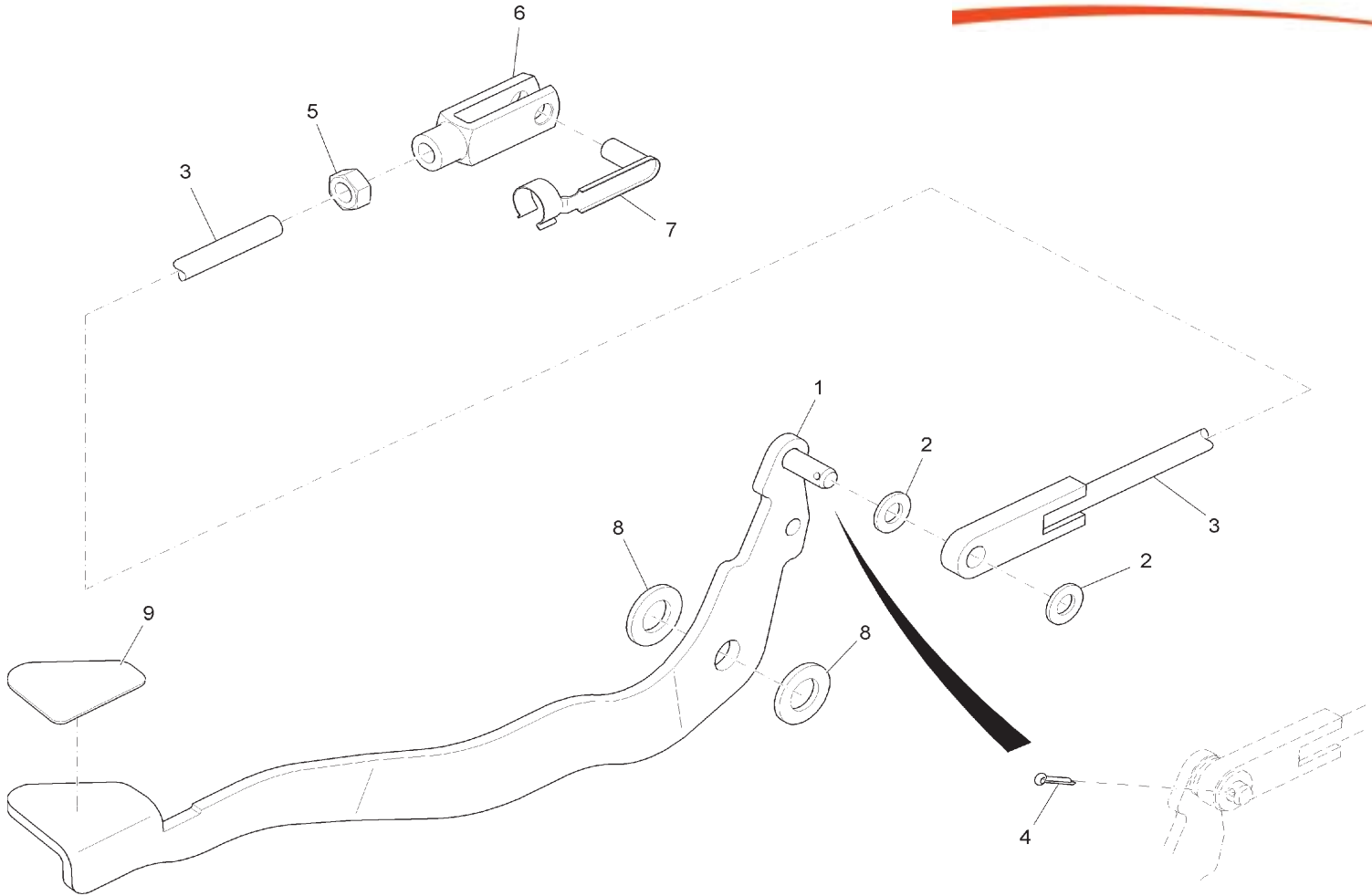

**Bill of Material - 99706218BT10-1**

Item	Spare part number	Mat. No.	Qty.	Description
1	01170020	96117361	1	Lifting pedal
2	00053760	12310058	2	Washer
3	01077930	96111877	1	Rod
4	00551410	13280110	1	Cotter pin
5	00053360	12022067	1	Hexagon nut
6	00925430	16055063	1	Fork yoke
7	00925420	13390042	1	Bolt
8	01078240	90510017	2	Washer
9	01078560	90518580	1	Decal

## Chassis Assembly I

### Brush Pressure Adjustment Subassembly

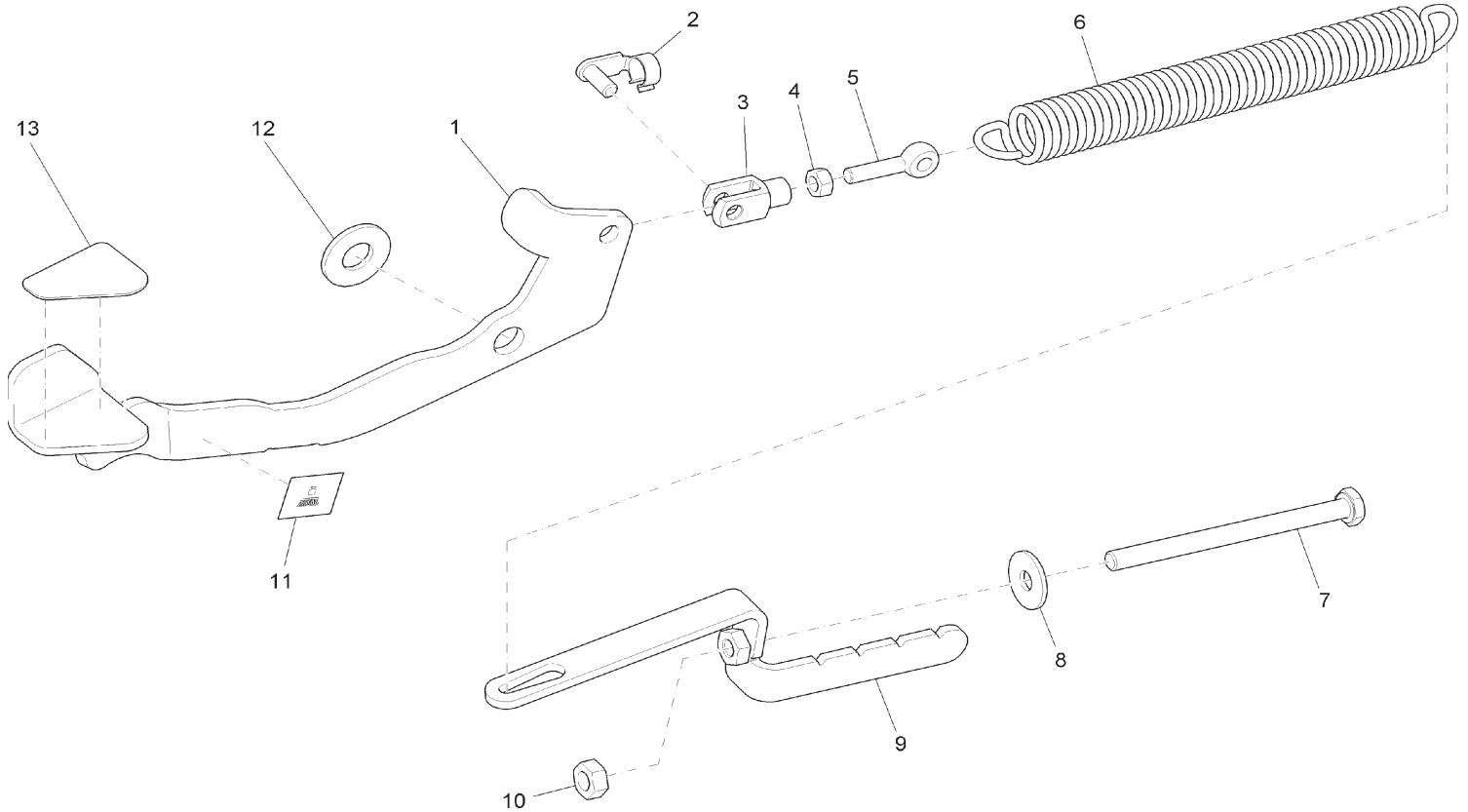

#### Bill of Material - 99706218BT10-2

Item	Spare part number	Mat. No.	Qty.	Description
1	01078550	96113949	1	Pedal
2	00151400	13390059	1	Bolt
3	00151440	16055089	1	Fork yoke
4	00053350	12022059	1	Hexagon nut
5	00735690	11518180	1	Eye bolt
6	01077770	90504242	1	Tension spring
7	01031550	11039716	1	Hexagon screw
8	01161070	12332152	1	Washer
9	01078500	96111505	1	Sheet metal
10	00704470	12022224	1	Hex. Nut
11	01074580	17264870	1	Decal BRUSH PRESSURE
12	01078240	90510017	1	Washer
13	01078560	90518580	1	Decal

**Chassis Assembly II**

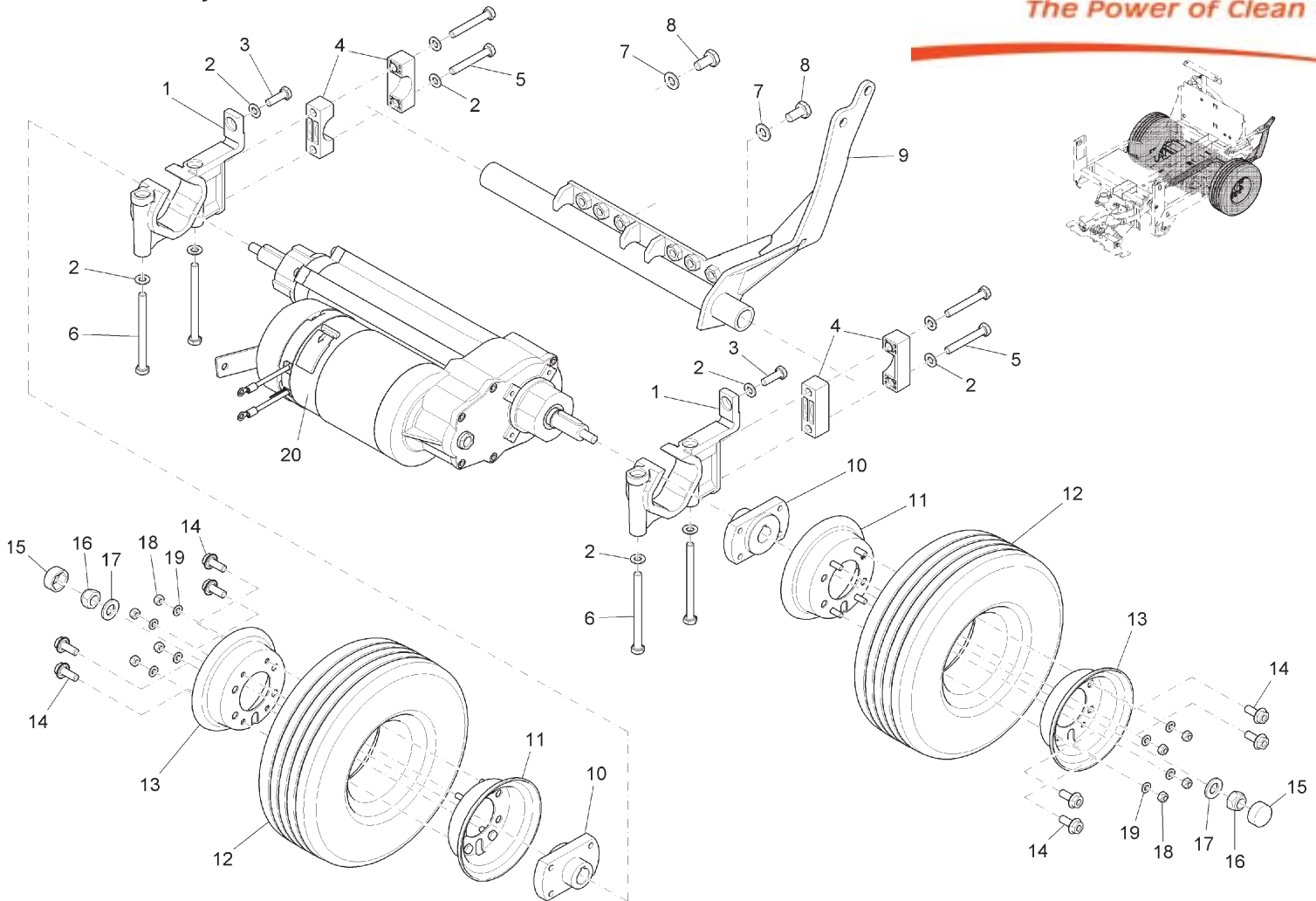

**Bill of Material - 99706218BT20**

Item	Spare part number	Mat. No.	Qty.	Description	Note
1	01078480	90512062	2	Bearing AMER	
2	00053750	12310041	10	Washer	
3	00053100	11038247	1	Hexagon screw	
4	01078020	90481664	4	Block	
5	00053260	11038296	4	Hex.bolt	
6	00053140	11032273	4	Hex.bolt	
7	00053760	12310058	2	Washer	
8	00021130	11038353	2	Hex.bolt	
9	01078490	96116009	1	Lever	
10	01078010	90510116	2	Hub	
11	00621690	96057013	2	Rim half	
12	01056130	90398165	2	Tyre	
13	00621710	90251869	2	Rim	
14	00959310	11717022	8	Hex.bolt	
15	01031540	15592058	2	protection cap	
16	00051490	12040077	2	Hexagon nut	
17	00053770	12310066	2	Washer	
18	00051520	12040044	8	Hexagon nut	
19	00053730	12310033	8	Washer	
20	01170340	90526021	1	Traction drive AMER	ITEM HAS SUBMODULES

**Chassis Assembly II**  
Traction Drive Motor Subassembly

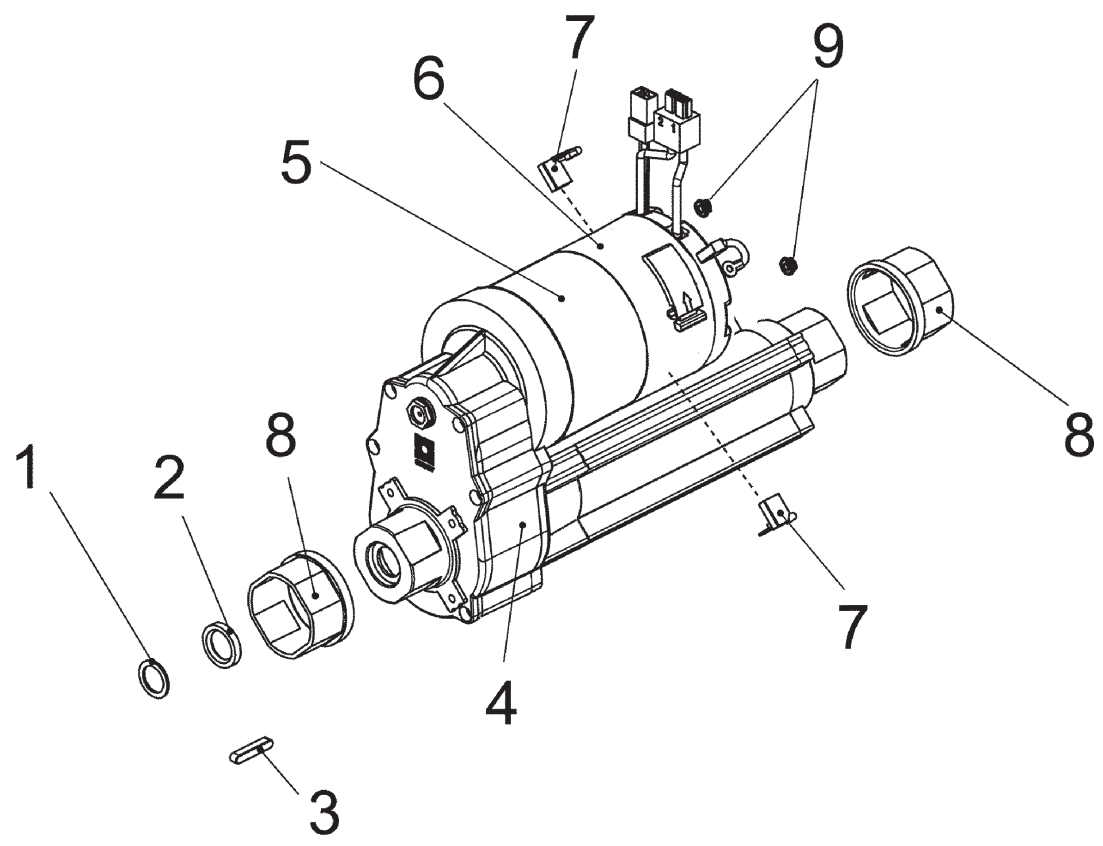

**Bill of Material - 01170340**

Item	Spare part number	Mat. No.	Qty.	Description
1	01077430	01077430	2	Washer
2	01077420	01077420	3	Gasket
3	01077410	01077410	2	Fitting key
4	01077390	01077390	1	Gear box with shaft
5	XXXXXXXX		1	no part-No.
6	01077360	01077360	1	Covering
7	01077350	01077350	4	Carbon brush
8	01077400	01077400	2	Bushing
9	01077380	01077380	4	Nut



# Chassis Assembly III

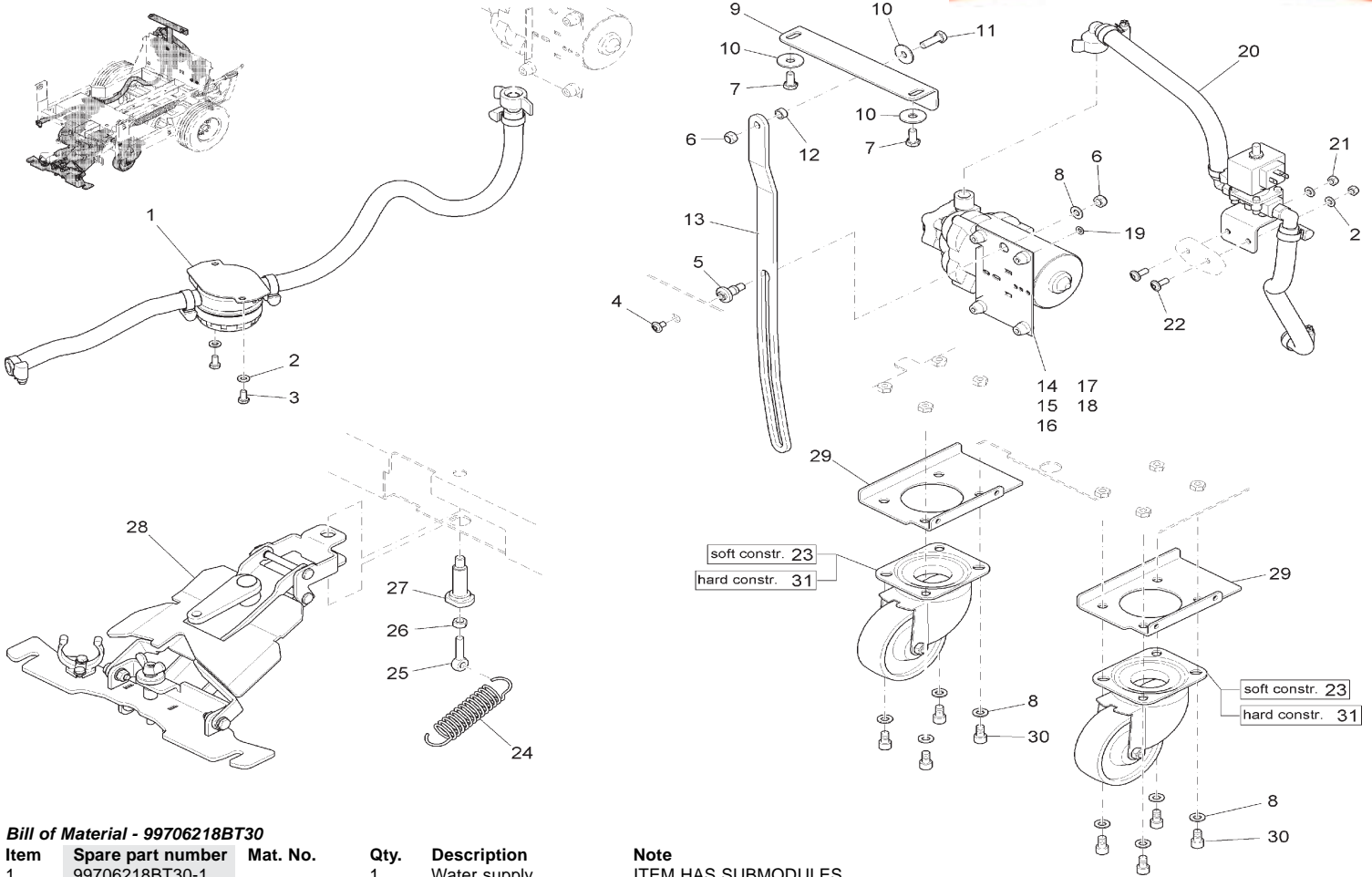

**Bill of Material - 99706218BT30**

Item	Spare part number	Mat. No.	Qty.	Description	Note
1	99706218BT30-1		1	Water supply	ITEM HAS SUBMODULES
2	00053730	12310033	4	Washer	
3	00104500	11038064	2	Hexagon screw	
4	01072520	11177179	1	Lens flange screw	
5	01077820	90513243	1	Bushing	
6	00051510	12040051	2	Hexagon nut	
7	00053080	11038197	10	Hexagon screw	
8	00053750	12310041	9	Washer	
9	01077760	90503160	1	Retainer	
10	00042900	12332029	3	Washer	
11	00053100	11038247	2	Hexagon screw	
12	01077700	90473158	1	Bushing	
13	01170260	90521824	1	Sheet metal	
14	00543750	90329095	1	Pump	
15	00559670	19725035	1	Case	
16	00083640	19791029	1	Plastic cover	
17	00083650	19791037	1	Plastic cover	
18	00903190	19724020	1	Tab	
19	00053720	12310025	1	Washer	
20	99706218BT30-2		1	Water supply	ITEM HAS SUBMODULES
21	00051520	12040044	2	Hexagon nut	Soft construction
22	01017640	11177060	2	Lens flange screw	
23	01079660	90495037	2	Steering roller	
24	01078150	90523333	1	Tension spring	
25	00735690	11518180	1	Eye bolt	
26	00046500	12012019	1	Hex. Nut	
27	01077830	90513573	1	Pivot	
28	03008100	97099915	1	Squeegee connection	ITEM HAS SUBMODULES
29	01170380	90527532	2	Sheet metal	
30	00103300	11126067	8	Socket head screw	
31	01079440	90537879	2	Steering roller	Hard construction

**Chassis Assembly III**  
**Water Supply Subassembly I**

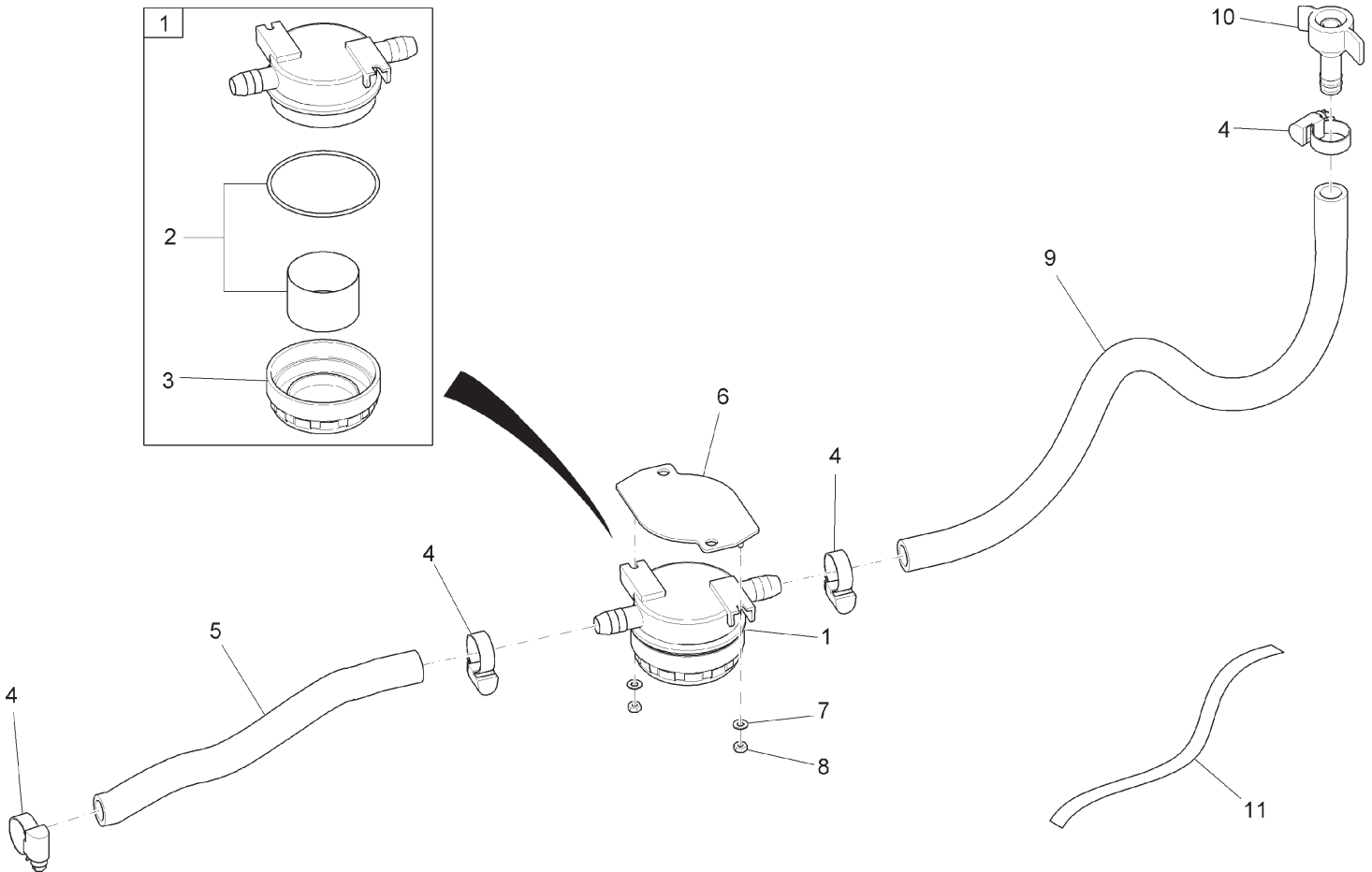

**Bill of Material - 99706218BT30-1**

Item	Spare part number	Mat. No.	Qty.	Description	Note
1	01077170	90522640	1	Water filter	
2	01079170	01079170	1	filter cartridge	cpl. with o-ring
3	XXXXXXXXXX		1	no part-No. yet	Filter cup
4	01015350	17533159	4	Hose clamp	
5	00200170	25842055	300mm	PVC hose	
6	01078510	96115035	1	Sheet metal	
7	00053710	12310017	2	Washer	
8	00133830	12040028	2	Hex. Nut	
9	00200170	25842055	480mm	PVC hose	
10	01071450	90432071	1	Screwing	
11	03007630	25743014	1	Sealing band	

**Chassis Assembly III**  
**Water Supply Subassembly II**

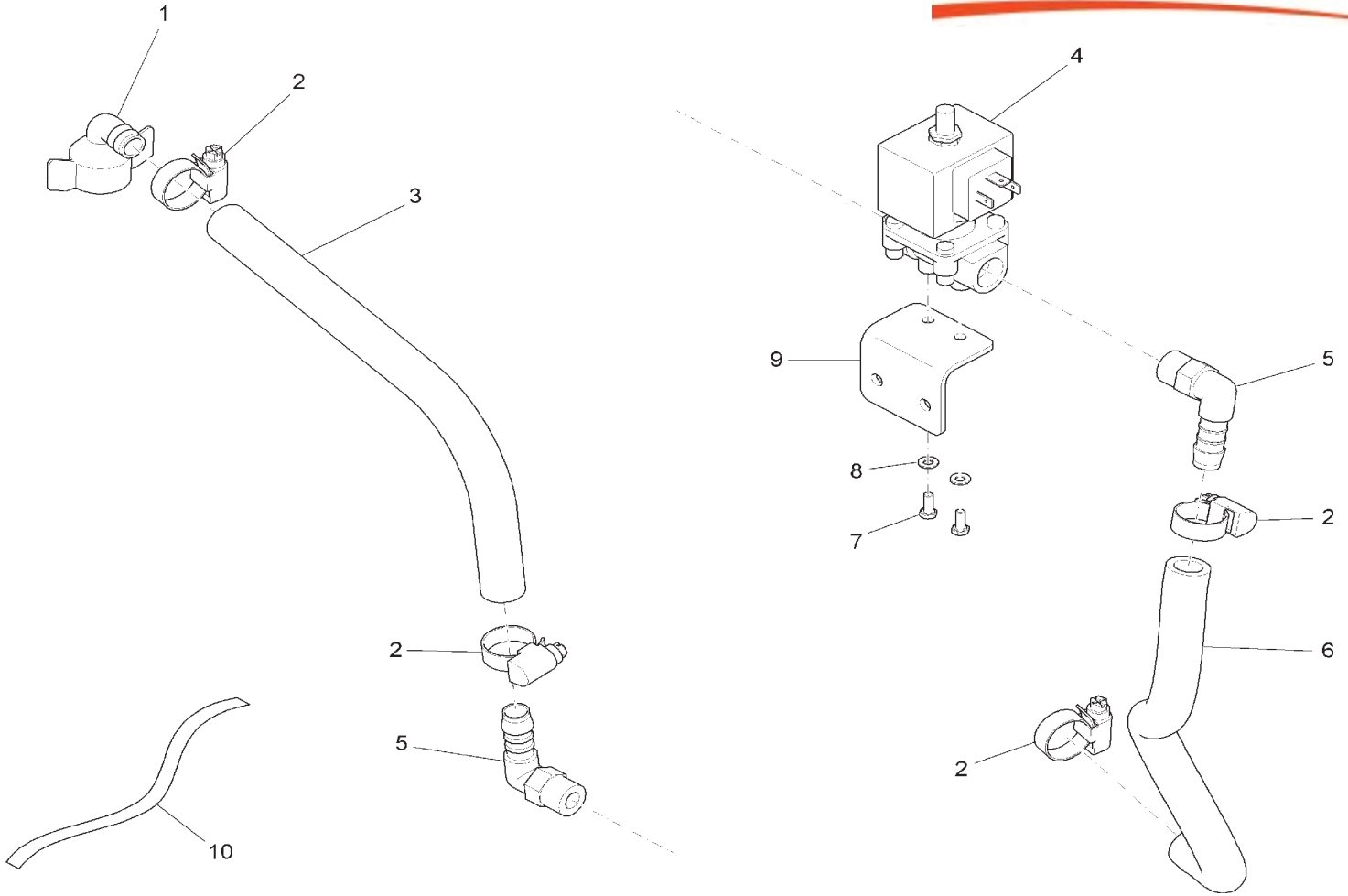

**Bill of Material - 99706218BT30-2**

Item	Spare part number	Mat. No.	Qty.	Description
1	00154140	90330168	1	Screwed angle fitting
2	01015350	17533159	4	Hose clamp
3	00200170	25842055	1	PVC hose
4	01071000	90435595	1	Electrovalve
5	00020020	90174970	2	Angle socket
6	00200170	25842055	1	PVC hose
7	00058580	11038965	2	Hex.bolt
8	00053710	12310017	2	Washer
9	01170030	90524885	1	Retainer
10	03007630	25743014	1	Sealing band

**Chassis Assembly III**  
Squeegee Connection Subassembly I

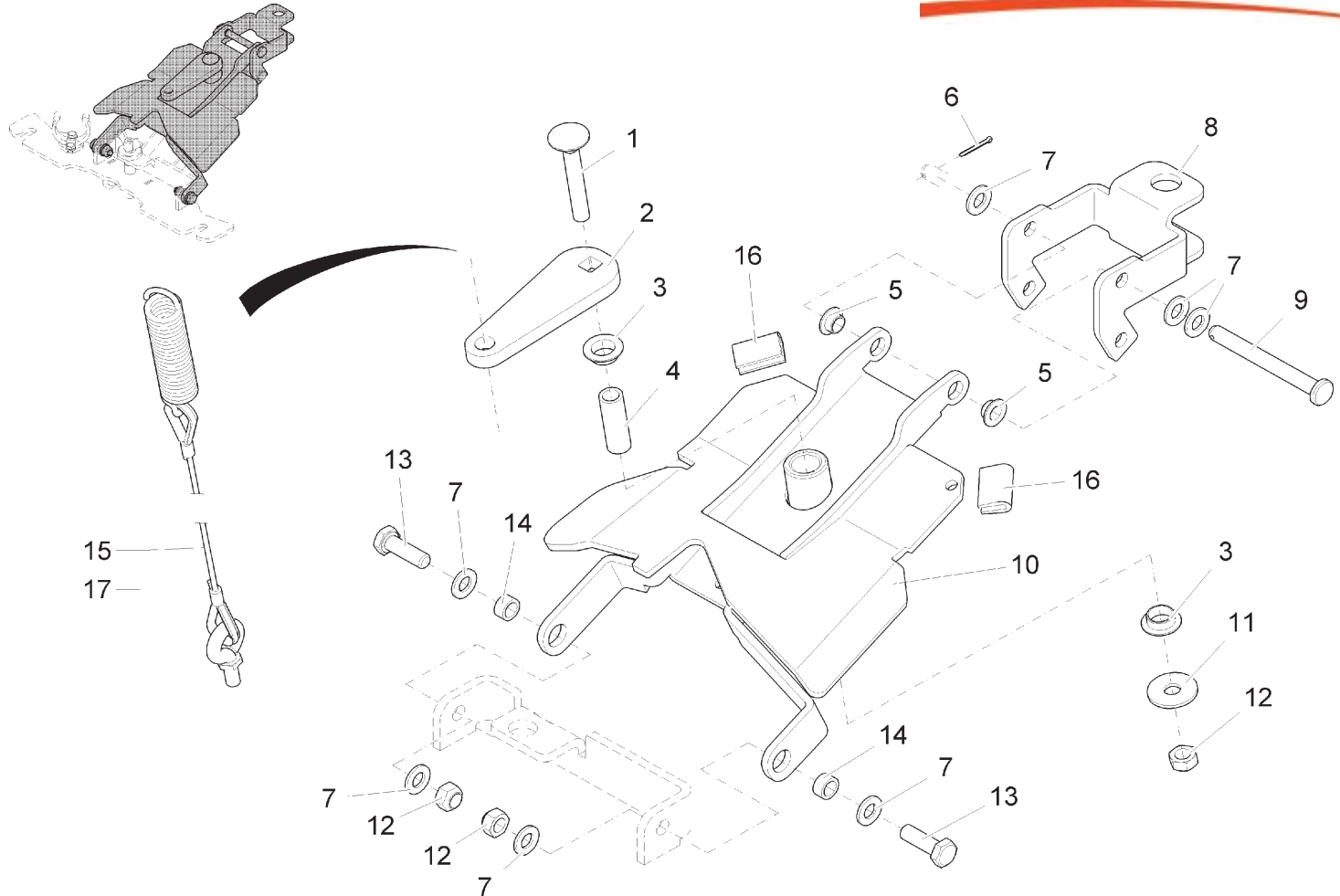

**Bill of Material - 03008100BT10**

Item	Spare part number	Mat. No.	Qty.	Description	Note
1	01130940	11620564	1	Cup head square neck bolt	
2	01170040	90521790	1	Sheet metal	
3	01077510	14895478	2	Slide bearing bush	
4	01170160	90204702	1	Pipe	
5	01078230	14895460	2	Slide bearing bush	
6	00054860	13280078	1	Cotter pin	
7	00053750	12310041	5	Washer	
8	01079280	90534710	1	Round part	
9	01078220	13328810	1	Bolt	
10	01079290	96117569	1	Sheet metal	
11	00042900	12332029	1	Washer	
12	00051510	12040051	3	Hexagon nut	
13	00053100	11038247	2	Hexagon screw	
14	01077700	90473158	2	Bushing	
15	01077980	96112370	1	Linkage	with E24, E26
16	00161240	25582024	1	Edge protection	
17	01170620	96117510	1	Linkage	with E28, E30, E33

**Chassis Assembly III**

**Squeegee Connection Subassembly Part II**

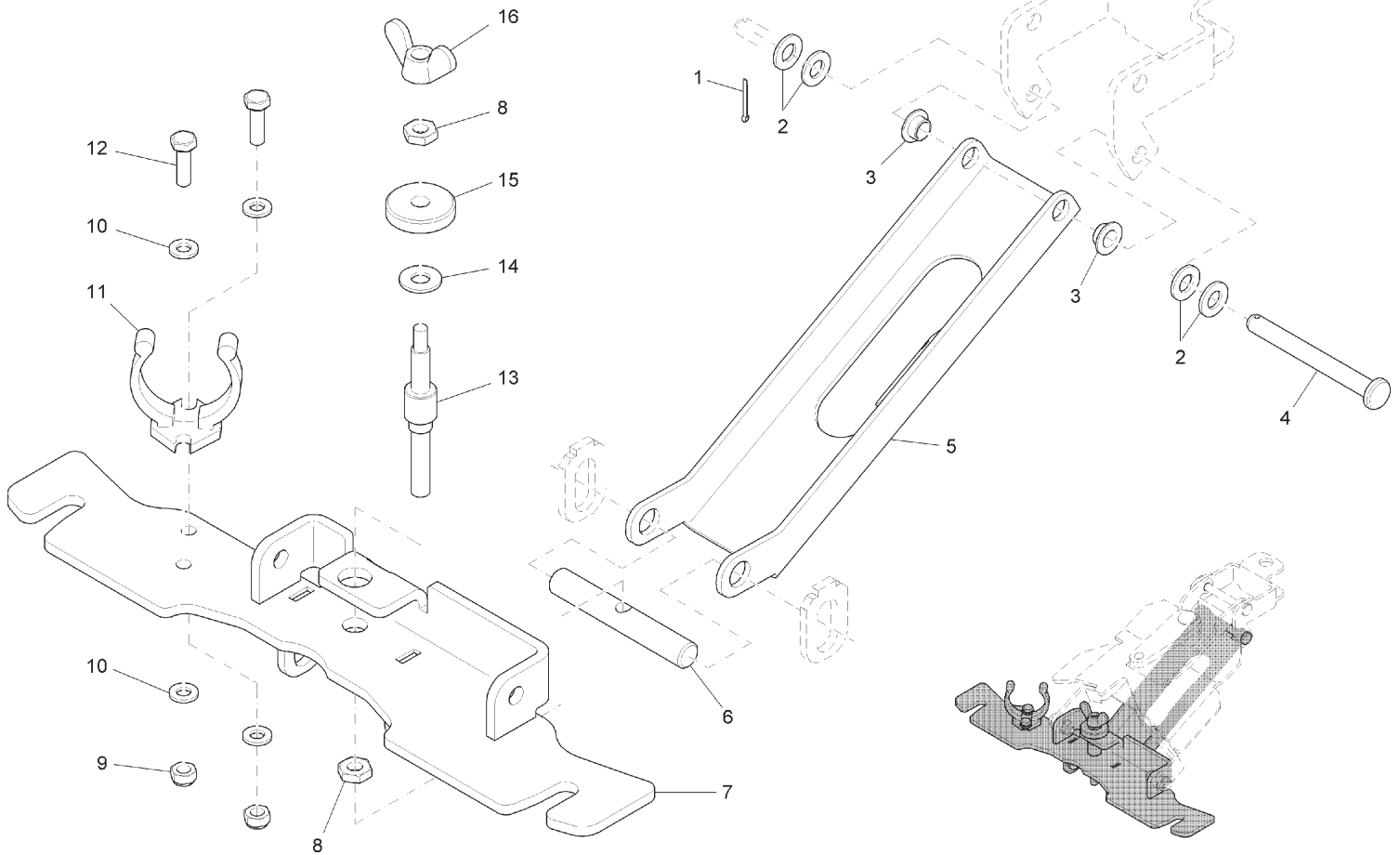

**Bill of Material - 03008100BT20**

Item	Spare part number	Mat. No.	Qty.	Description
1	00054860	13280078	1	Cotter pin
2	00053750	12310041	1	Washer
3	01078230	14895460	2	Slide bearing bush
4	01170050	13328935	1	Bolt
5	01079320	90495805	1	Draft link
6	01077680	90467686	1	Bolt
7	01079330	96110242	1	Sheet metal
8	00046500	12012019	2	Hex. Nut
9	00051520	12040044	2	Hexagon nut
10	00053730	12310033	4	Washer
11	01078120	90503251	1	Hose support
12	00053020	11038098	2	Hexagon screw
13	01077850	90515149	1	Threaded pin
14	00042900	12332029	1	Washer
15	00051510	12040051	1	Hexagon nut
16	00054020	12158028	1	Wing nut
17	00053330	12022042	1	Hexagon nut

**Battery Tray Assembly**

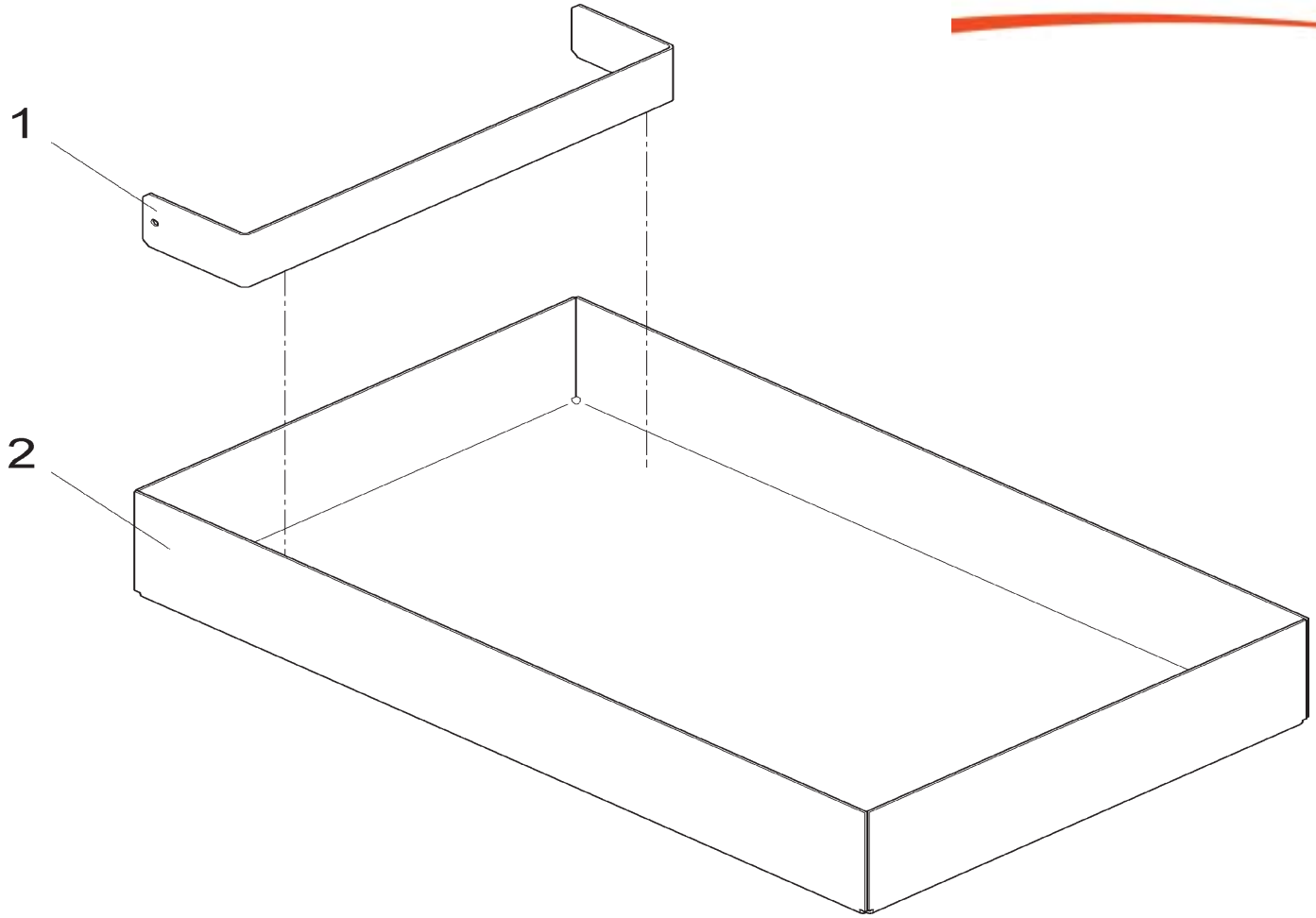

**Bill of Material - 99706218BT40**

Item	Spare part number	Mat. No.	Qty.	Description
1	01170760	90535360	1	Sheet metal
2	03008190	96117171	1	Battery tray

## Solution Tank Assembly

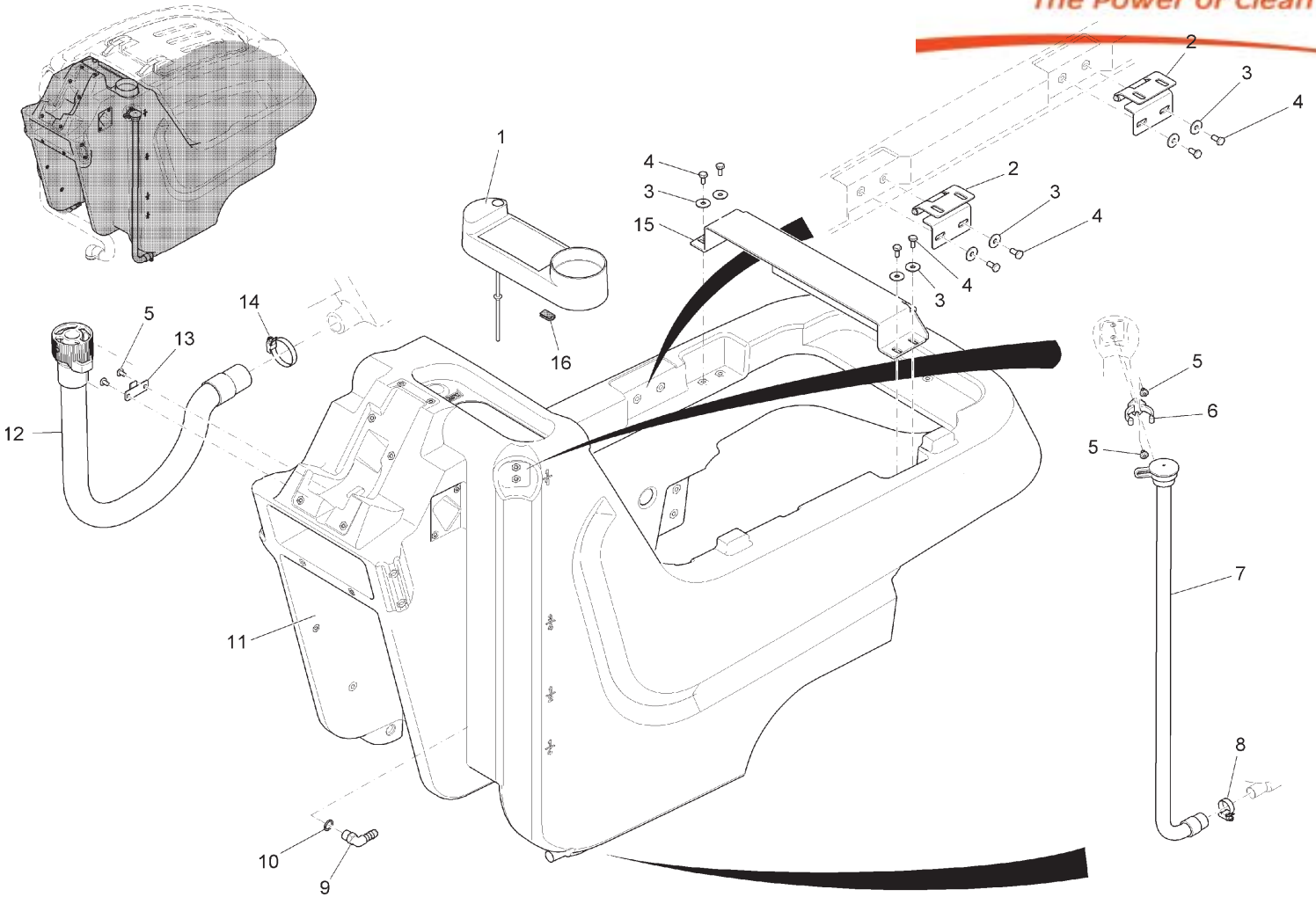

### Bill of Material - 99706218BT50

Item	Spare part number	Mat. No.	Qty.	Description
1	01078100	96114061	1	Fresh water cap
2	01078110	90496910	2	Hinge
3	00047990	12515086	4	Disk wheel
4	00053080	11038197	8	Hexagon screw
5	01072520	11177179	4	Lens flange screw
6	01078120	90503251	1	Hose support
7	01170530	96110622	1	Hose
8	01161690	17533290	1	Clamp
9	00020020	90174970	1	Angle socket
10	00057720	15286149	1	O-ring oil resistant
11	01073820	96116025	1	Fresh water tank
12	99706218BT50-1		1	Foul water hose cpl.
13	01077860	90517574	1	Hook
14	00751160	17533043	1	Hose clamp
15	XXXXXXXX	96116736	1	Traverse
16	00721090	25583022	710mm	Edge protection

**Solution Tank Assembly**

Recovery Tank Drain Hose Subassembly

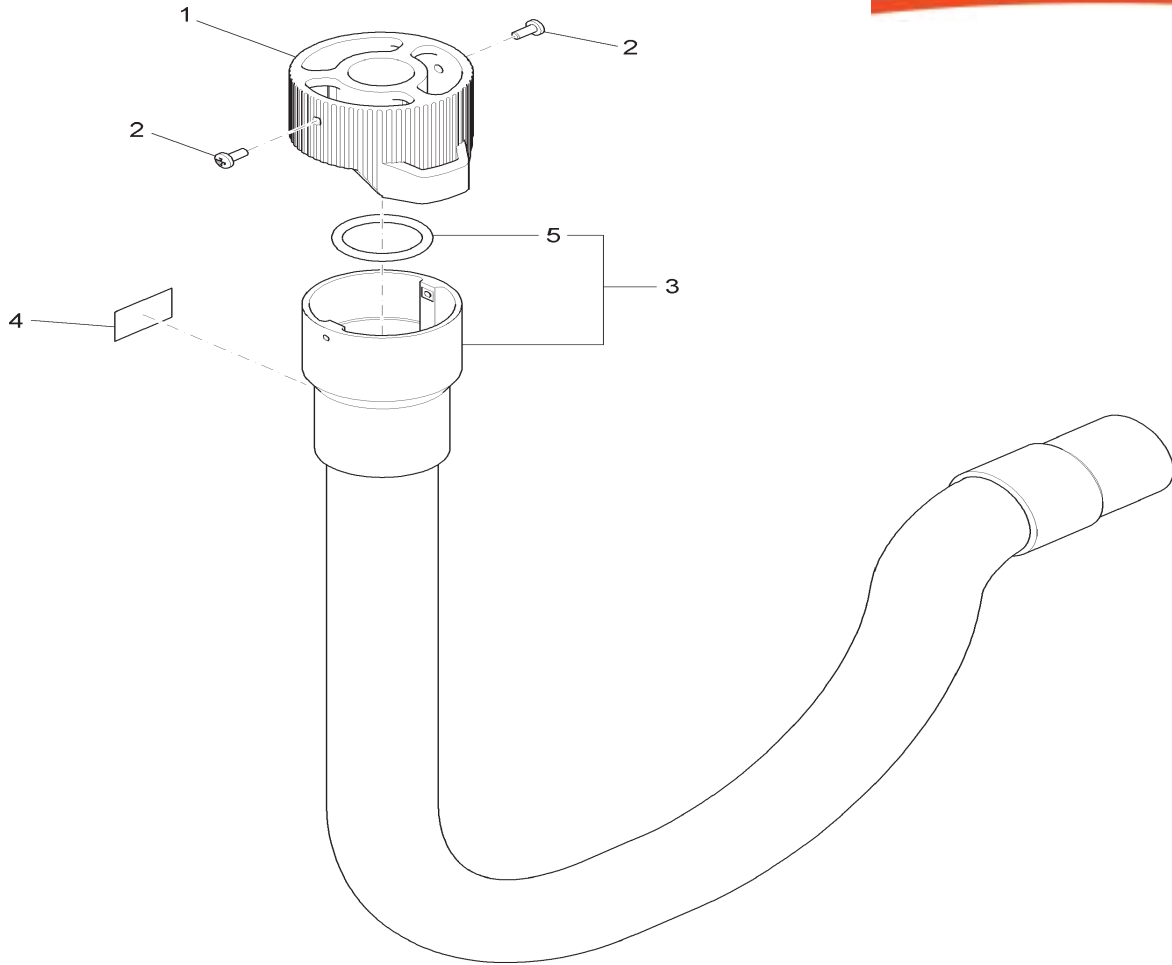

**Bill of Material - 99706218BT50-1**

Item	Spare part number	Mat. No.	Qty.	Description
1	00906110	90304528	1	Cover
2	00906100	11175395	2	Fillister-head screw
3	01077960	97090096	1	Foul water hose
4	01170060	17264888	1	Decal FOUL WATER
5	01079300	15282072	1	O-Ring



# Recovery Tank Assembly

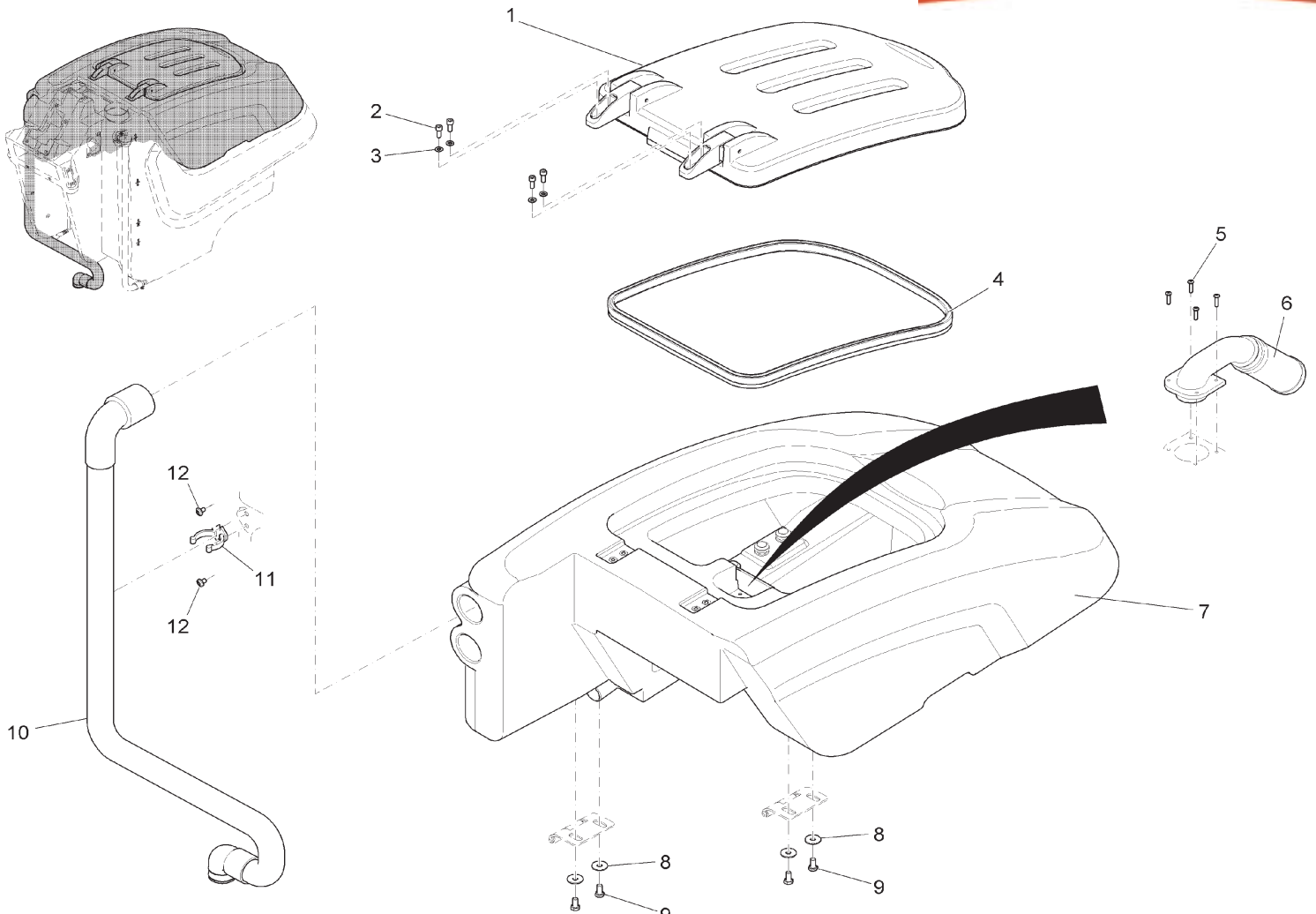

**Bill of Material - 99706218BT60**

Item	Spare part number	Mat. No.	Qty.	Description
1	01077990	97092951	1	Cover
2	00136910	11126166	4	Cylinder head screw
3	00053730	12310033	4	Washer
4	01071770	25510512	1580mm	Sealing profile
5	01078160	11709151	4	Screw
6	01078250	97093843	1	Filter unit
7	01170770	96116017	1	Foul water tank
8	00047990	12515086	4	Disk wheel
9	00053080	11038197	4	Hexagon screw
10	01077920	96111349	1	Suction hose
11	01078120	90503251	1	Hose support
12	01072520	11177179	2	Lens flange screw

# Vacuum Motor Assembly

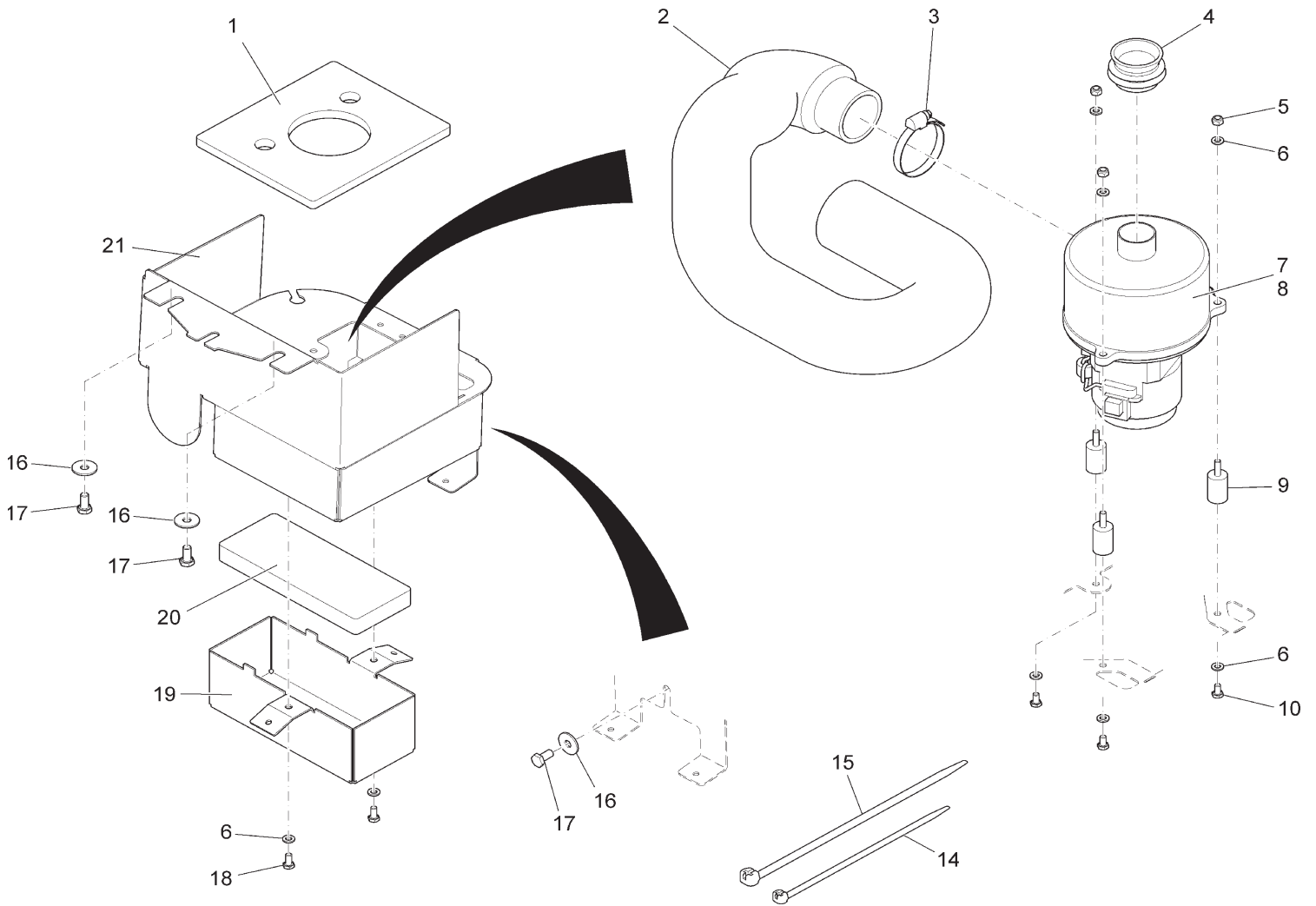

**Bill of Material - 99706218BT70**

Item	Spare part number	Mat. No.	Qty.	Description
1	01079740	90523945	1	Insulation mat
2	01077900	90519737	1	Hose
3	00732130	17533027	1	Hose clamp
4	01078180	90503657	1	Connection
5	00051520	12040044	3	Hexagon nut
6	00053730	12310033	8	Washer
7	01079350	97096200	1	Suction motor
8	01074610	01074610	4	Carbon brush
9	01078190	90518457	3	Buffer
10	00025260	11038056	3	Hexagon screw
14	00121150	90114810	1	Cable tie
15	00967760	90156688	4	Cable tie
16	00042900	12332029	3	Washer
17	00053080	11038197	3	Hexagon screw
18	00104500	11038064	2	Hexagon screw
19	01079750	90519653	1	Cover
20	01079730	90519745	1	Insulation mat
21	03007810	96114301	1	Sheet metal

# Squeegee Lift Handle Assembly

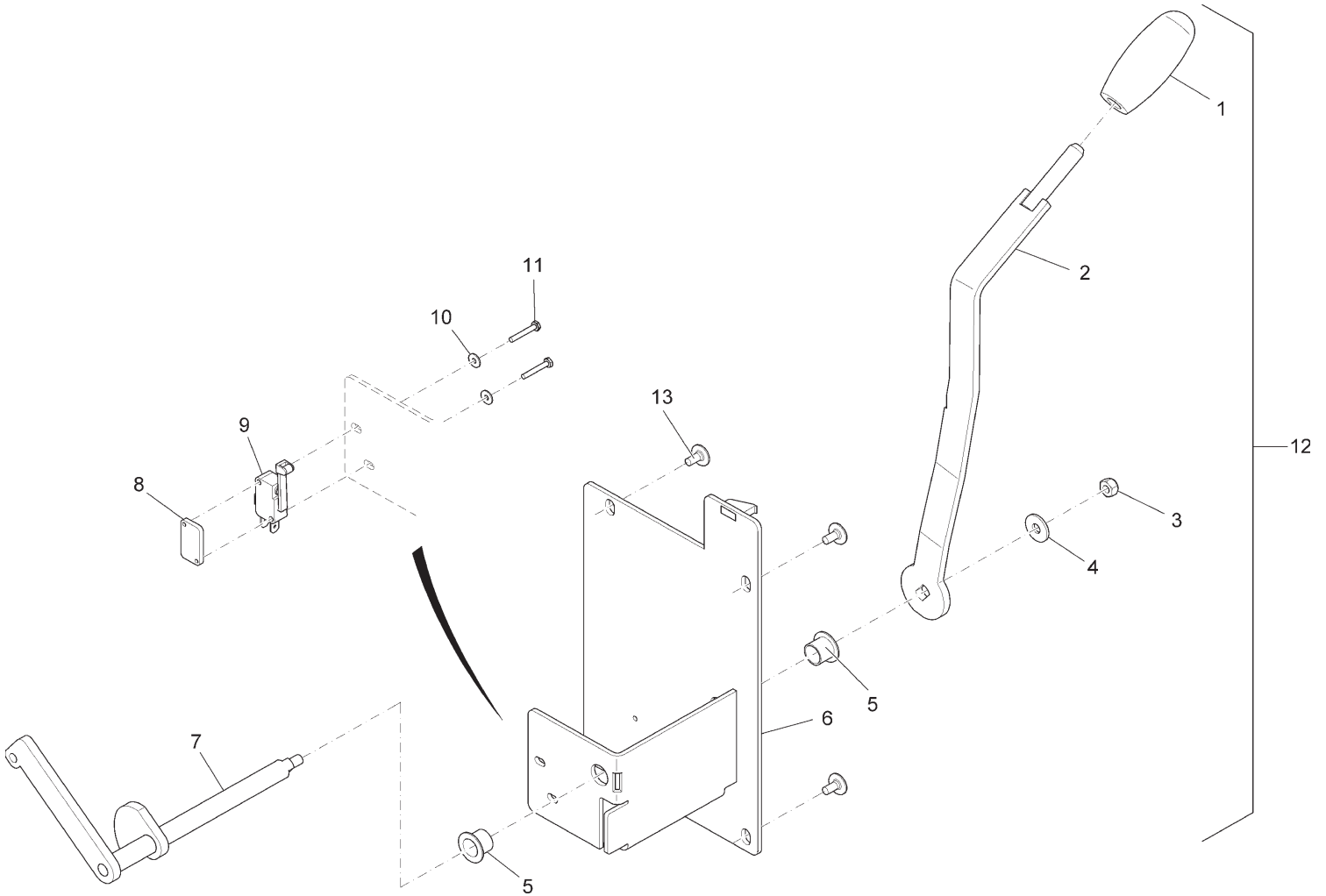

**Bill of Material - 99706218BT80**

Item	Spare part number	Mat. No.	Qty.	Description
1	00705560	17143025	1	Handle
2	01079160	96113493	1	Lever
3	00051520	12040044	1	Hexagon nut
4	00135120	12332011	1	Washer
5	01071440	14895288	2	Plain bearing bush
6	01079710	96110804	1	Support plate
7	01079720	96110705	1	Shaft with cam
8	01074840	90471483	1	Thread base plate
9	00975510	90306002	1	Micro switch
10	00747400	12332110	2	Washer
11	00022180	11039088	2	Hex.bolt
12	00009000	97092340	1	Lifting suction unit
13	01072520	11177179	4	Lens flange screw

# Squeegee Lock Assembly

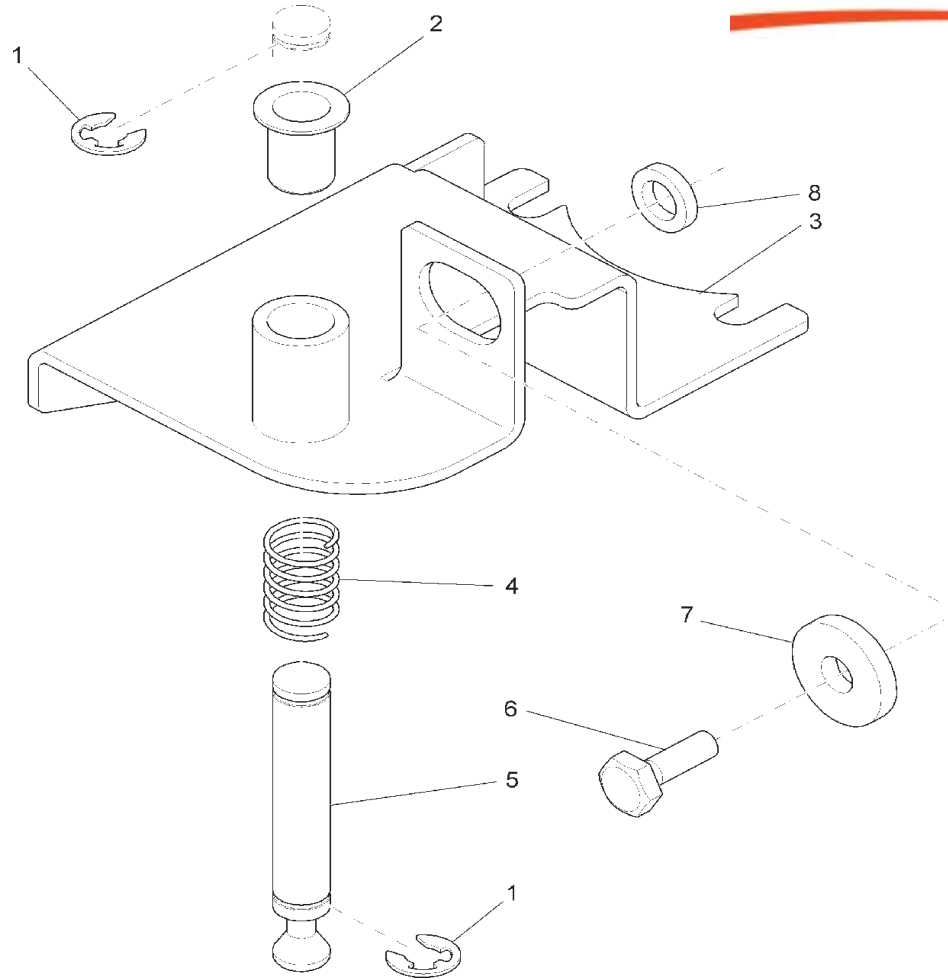

**Bill of Material - 99706218BT90**

Item	Spare part number	Mat. No.	Qty.	Description
1	00046280	12640033	2	Thrust washer
2	00041400	14895122	1	Plain bearing bush
3	01170730	96115076	1	Folding plate
4	01170280	90523325	1	Cyl.compression spring
5	01170270	90523036	1	Pin
6	00053090	11038213	1	Hexagon screw
7	00047990	12515086	1	Disk wheel
8	01079670	90525692	1	Spacer sleeve

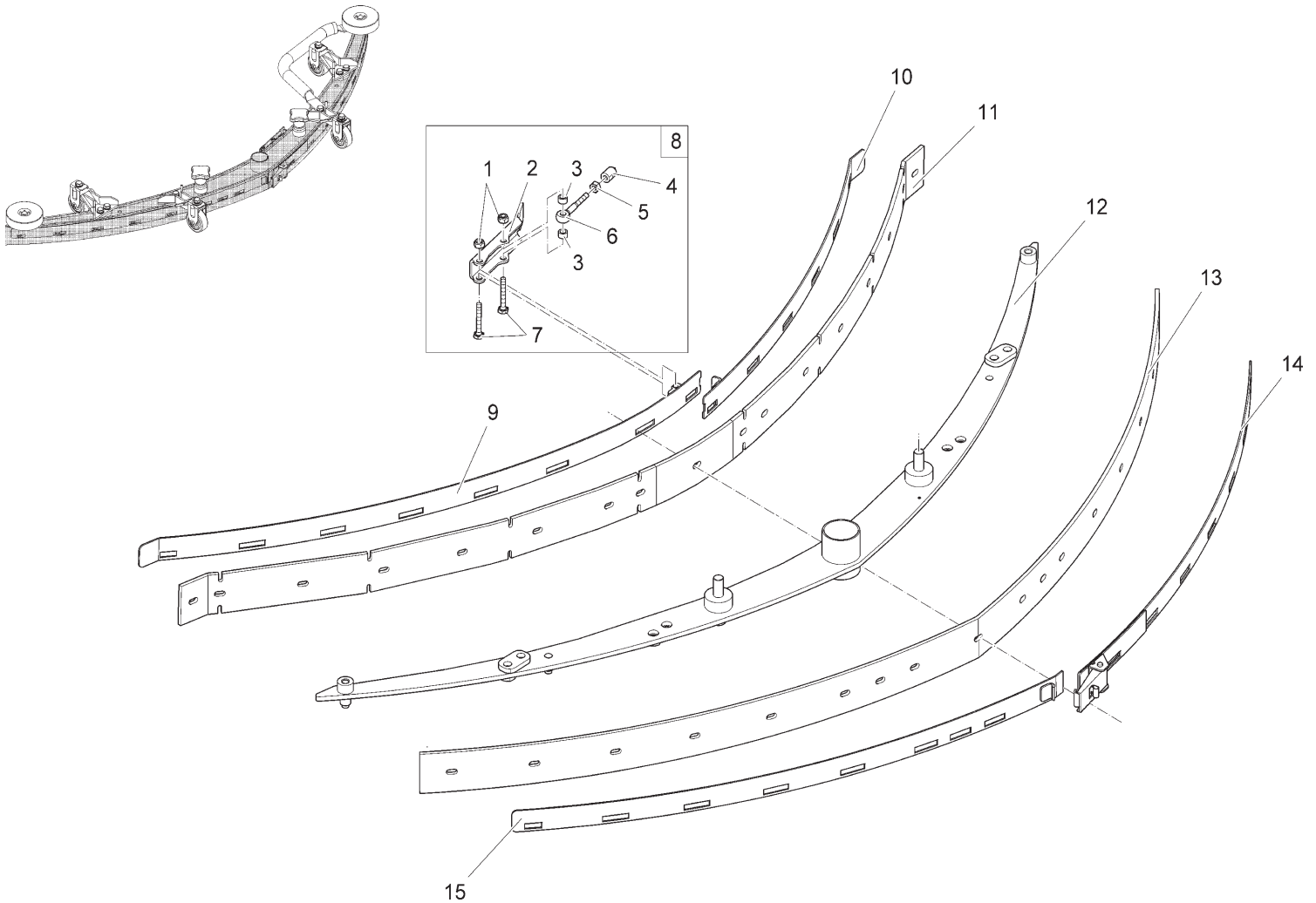

**Bill of Material - 99706218BT100**

Item	Spare part number	Mat. No.	Qty.	Description
1	01017660	12040283	2	Hex. Nut
2	01077580	90535758	1	Lever
3	01077590	90514506	2	Bushing
4	01078090	90513631	1	Pressure piece
5	00902250	12022430	1	Hex. Nut
6	01077500	11518313	1	Eye bolt
7	01079890	11039765	2	Hexagon screw
8	00009010	97057459	1	Lock suction unit
9	01079880	96114830	1	Front tension band
10	01079870	96114822	1	Front tension band
11	01079790	90522251	1	Slot strip
12	01079900	96114814	1	Suction unit 1110mm
13	01079780	90522269	1	Sealing strip
14	01079910	96114855	1	Rear tension band
15	01079920	96114848	1	Rear tension band

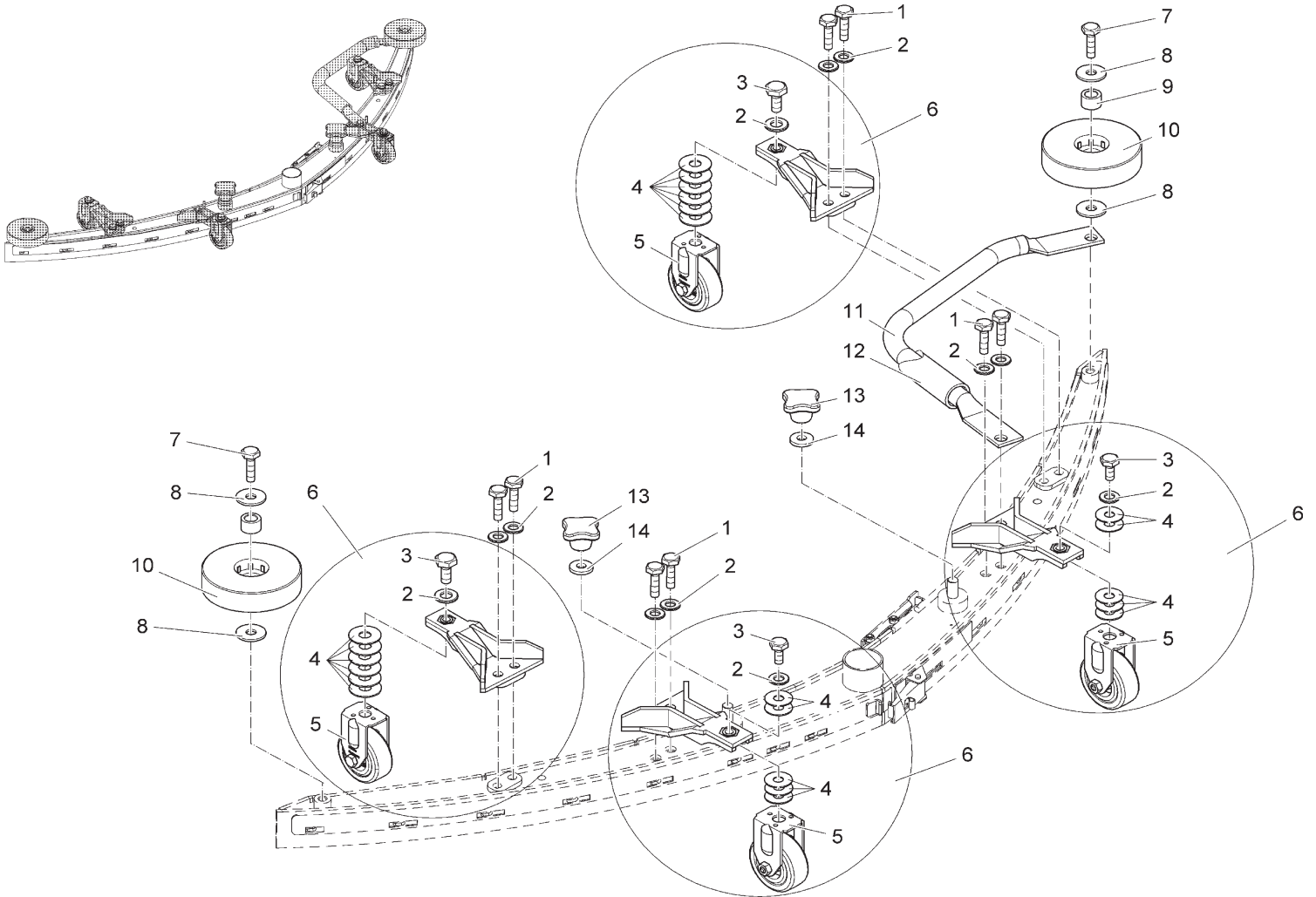

**Bill of Material - 99706218BT110**

Item	Spare part number	Mat. No.	Qty.	Description
1	01078690	11038924	4	Hexagon screw
2	00101550	12310264	12	Washer
3	01071740	11039609	4	Hex.bolt
4	01079080	90531112	22	Spacer
5	01077810	90513094	4	Fixed castor
6	01079070	97098842	2	Fixed castor,cpl.
7	01059530	11039567	2	Hexagon screw
8	00902280	12332136	4	Washer
9	00879030	90199019	2	Pipe
10	00924810	90336637	2	Deflector roller
11	01079930	90522566	1	Bracket
12	00911270	25842105	305 mm	Hose
13	00866720	17133026	2	Star handle
14	00972060	12515094	2	Disk wheel

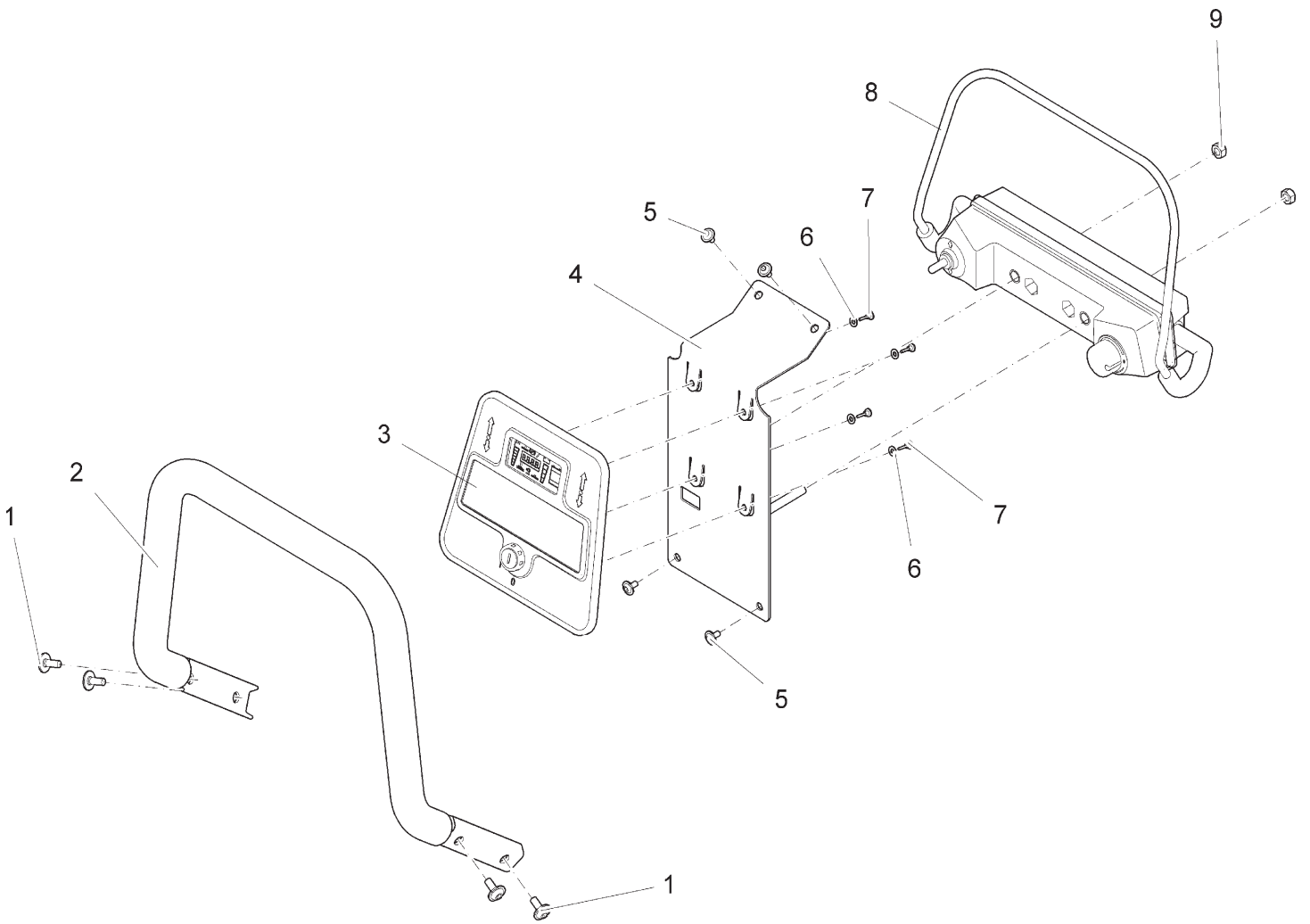

**Bill of Material - 99706218BT120**

Item	Spare part number	Mat. No.	Qty.	Description	Note
1	01074320	11177187	4	Lens flange screw	
2	01079760	90494501	1	Handle bar	
3	99706218BT120-1		1	Console	ITEM HAS SUBMODULES
4	01079770	96117585	1	Sheet metal	
5	01072520	11177179	4	Lens flange screw	
6	00874720	12310272	4	Washer	
7	00961490	11709011	4	Self tapping screw	
8	01079950	97096069	1	Bail system	
9	00051510	12040051	2	Hexagon nut	

**Control Panel Assembly**  
Console Subassembly

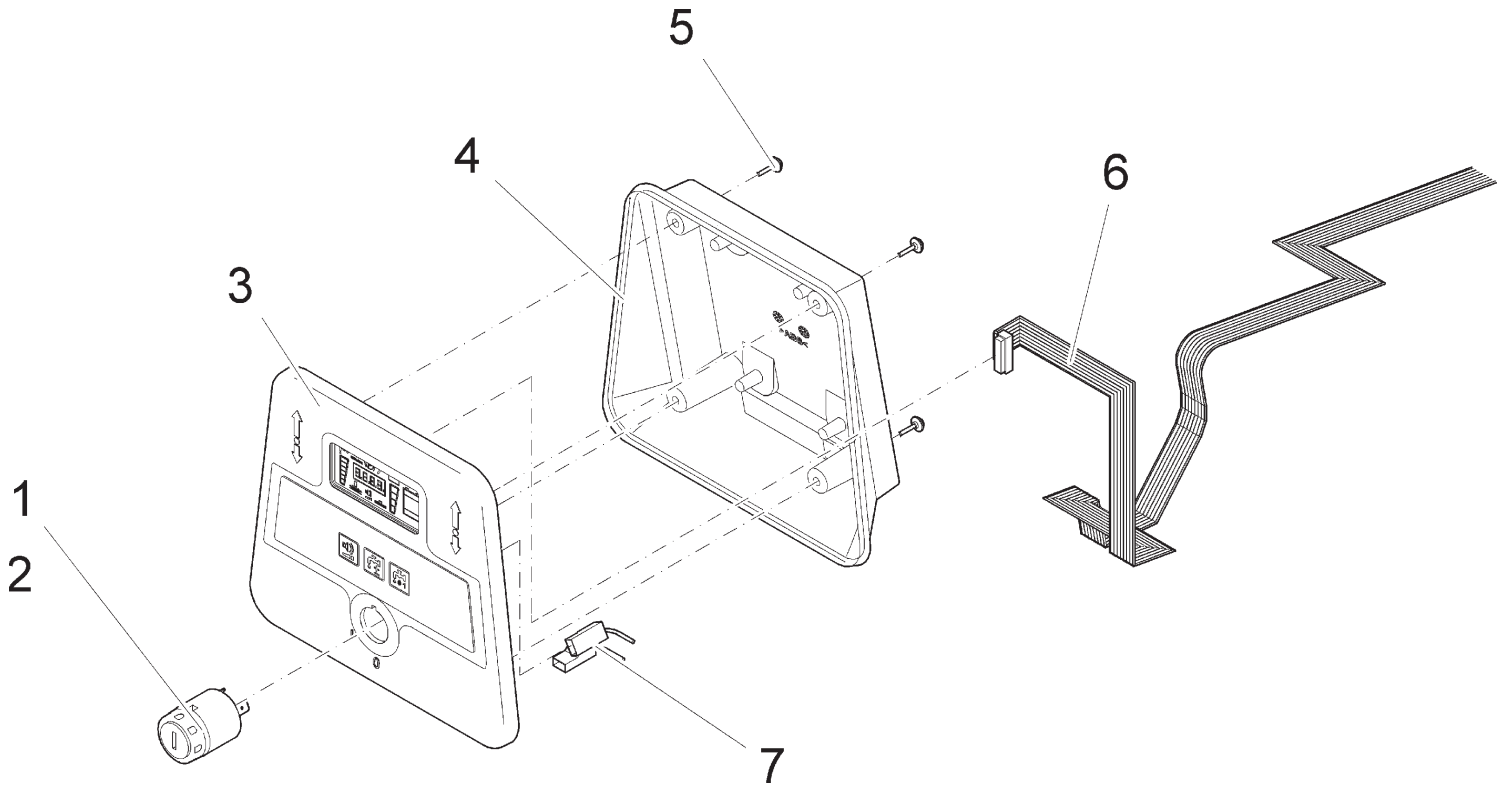

**Bill of Material - 99706218BT120-1**

Item	Spare part number	Mat. No.	Qty.	Description
1	00021710	90323437	1	Key switch
2	00745890	00745890	1	Set (2pc.) key
3	01079090	97057160	1	Console B70/B90
4	01078940	90499492	1	Console
5	01078860	11702123	4	Screw
6	01078930	90511130	1	Ribbon cable
7	01078950	90518150	1	Cable key switch



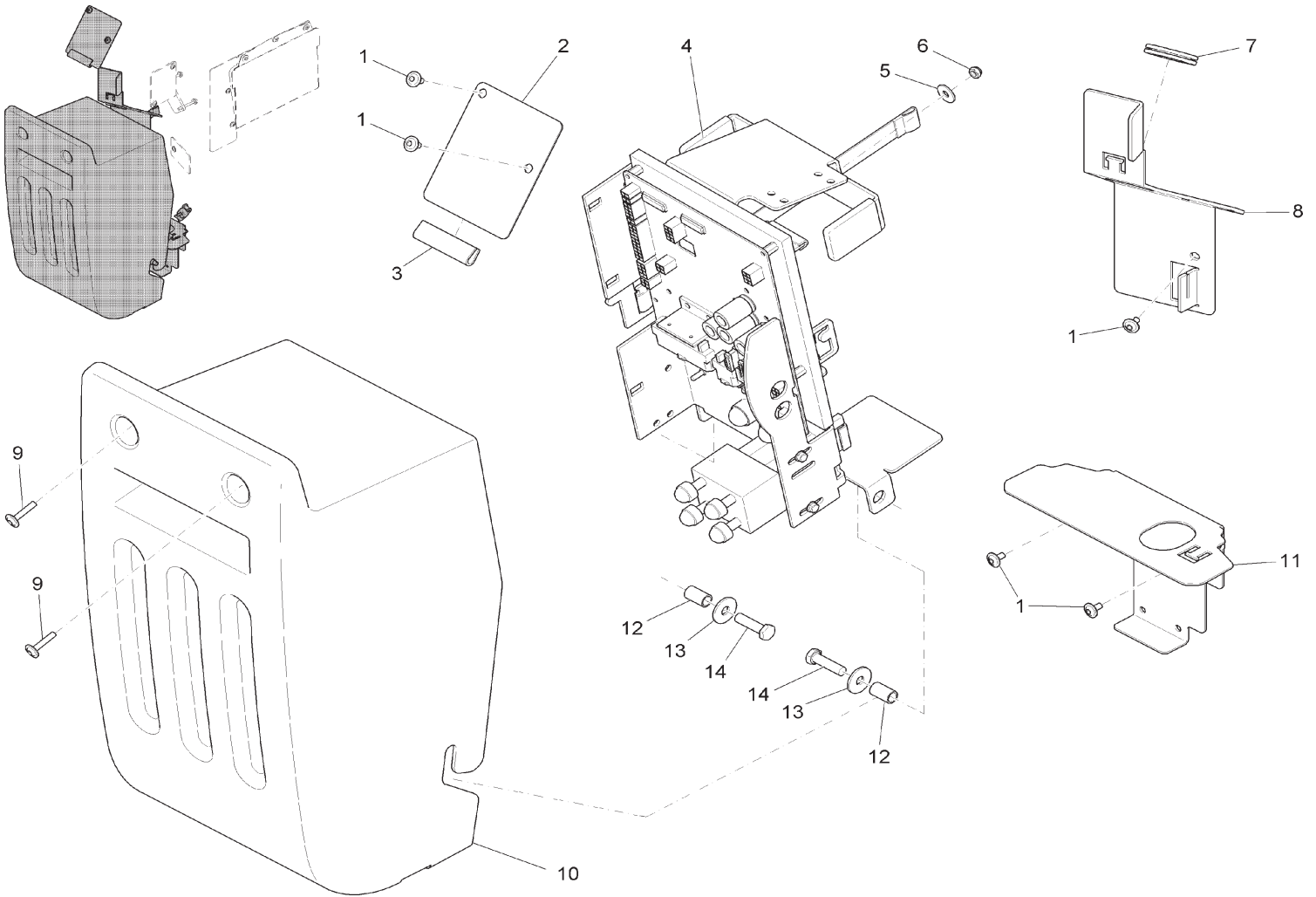

**Bill of Material - 99706218BT130**

Item	Spare part number	Mat. No.	Qty.	Description	Note
1	01072520	11177179	5	Lens flange screw	
2	01078570	90509803	1	Sheet metal	
3	00161240	25582024	60mm	Edge protection	
4	99706218BT130-1		1	Retainer cpl.	ITEM HAS SUBMODULES
5	00153200	12347027	1	Washer	
6	00051520	12040044	1	Hexagon nut	
7	01079690	15595259	1	Bushing	
8	01078580	90511338	1	Sheet metal	
9	01082530	11177161	2	Lens flange screw	
10	01078270	96114996	1	Covering	
11	01078590	90513912	1	Clamping plate	
12	01078260	90499377	2	Bushing	
13	00042900	12332029	2	Washer	
14	00053110	11038254	2	Hexagon screw	

**Electrical Assembly I**  
Retainer Subassembly

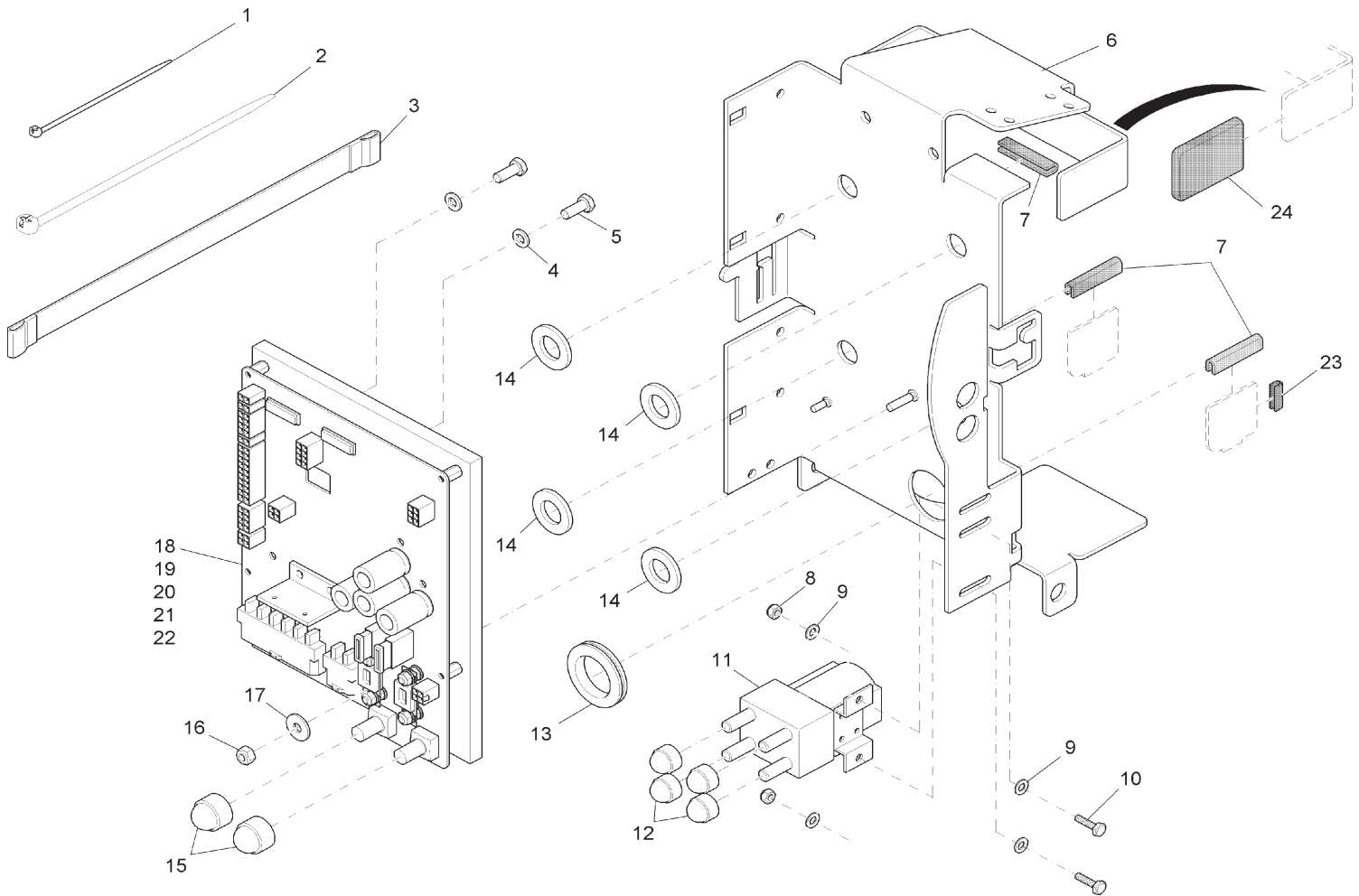

**Bill of Material - 99706218BT130-1**

Item	Spare part number	Mat. No.	Qty.	Description
1	00967760	90156688	4	Cable tie
2	00121150	90114810	8	Cable tie
3	01077880	90517699	1	Webbing
4	00053730	12310033	2	Washer
5	00053010	11038072	2	Hex.bolt
6	01078640	96117668	1	Retainer
7	00721090	25583022	120mm	Edge protection
8	00051340	12040036	2	Hexagon nut
9	00053720	12310025	4	Washer
10	00054410	11038049	2	Hex.bolt
11	01170460	90529942	1	Contactor
12	00131610	15592033	4	Lens cap
13	01079690	15595259	1	Bushing
14	01078240	90510017	4	Washer
15	00747210	15592041	2	Lens cap
16	00051520	12040044	1	Hexagon nut
17	00135120	12332011	1	Washer
18	01079140	97057384	1	Controller E24/E26 with Package
19	00972420	00972420	0	Strip fuse
20	00902440	00902440	0	Strip fuse
21	00733630	19731082	0	Fuse
22	00972430	00972430	0	Fuse
23	00721090	25583022	30mm	Edge protection
24	01074240	90463746	2	Cap

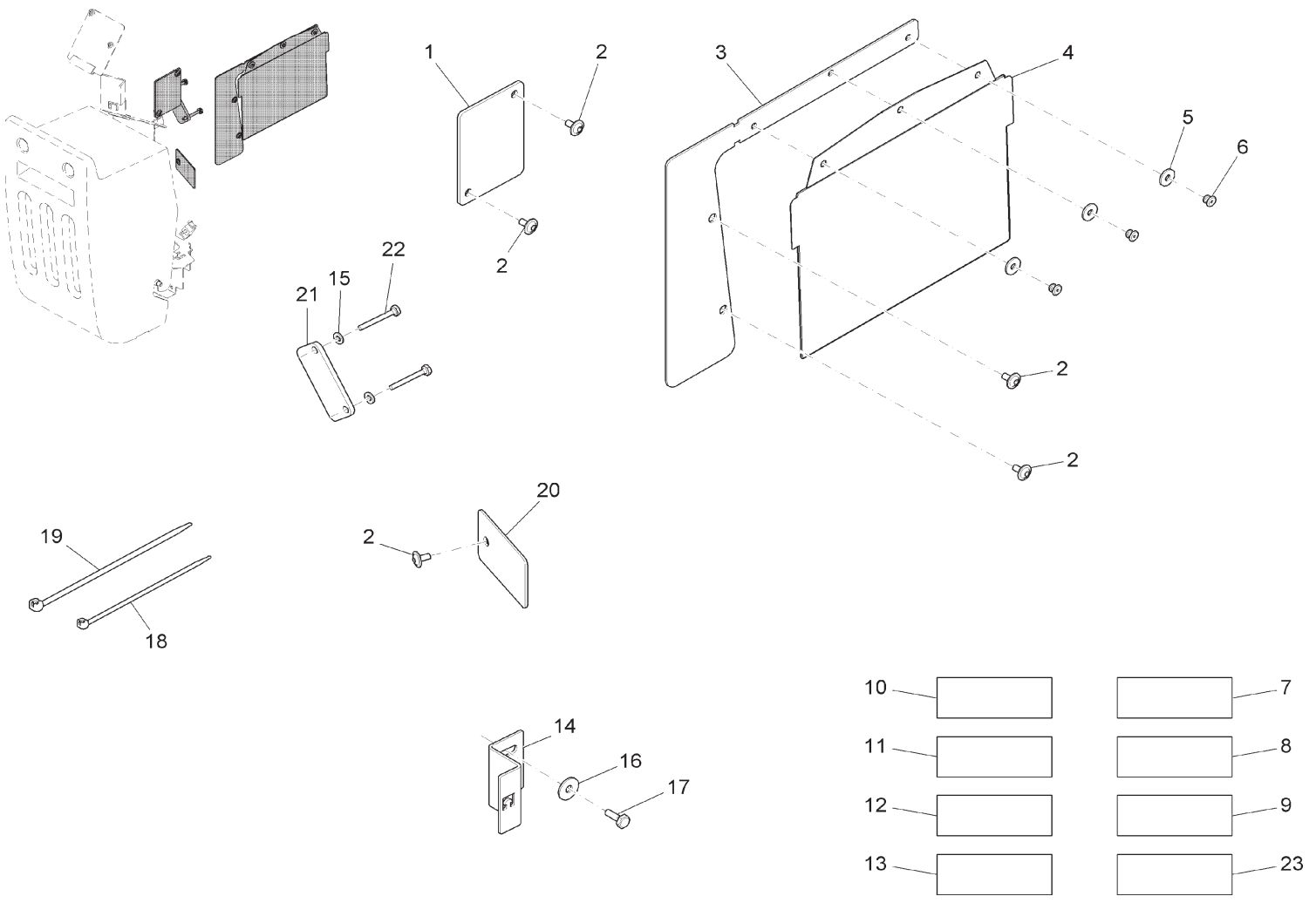

**Bill of Material - 99706218BT140**

Item	Spare part number	Mat. No.	Qty.	Description
1	01078600	90518119	1	Covering
2	01072520	11177179	7	Lens flange screw
3	01078610	90511346	1	Sheet metal
4	01078280	90465774	1	Bag
5	00555520	12332052	3	Washer
6	01078290	13165196	3	Blind rivet
7	03008120	97096986	1	Wiring harness W1
8	03008130	97096994	1	Wiring harness W2
9	03008200	97101547	1	Wiring harness W3
10	03007790	97099063	1	Wiring harness
11	03008160	97098511	1	Wiring harness W11
12	03008170	97095129	1	Cable loom
13	03008180	97098529	1	Cable loom
14	01170450	90529876	1	Clamping plate
15	00053730	12310033	2	Washer
16	00042900	12332029	1	Washer
17	00053090	11038213	1	Hexagon screw
18	00121150	90114810	10	Cable tie
19	00967760	90156688	2	Cable tie
20	01078630	90511320	1	Sheet metal
21	01170500	90538125	1	Distance plate
22	00535110	11038817	2	Hex.bolt
23	03007780	97099048	1	Cable loom

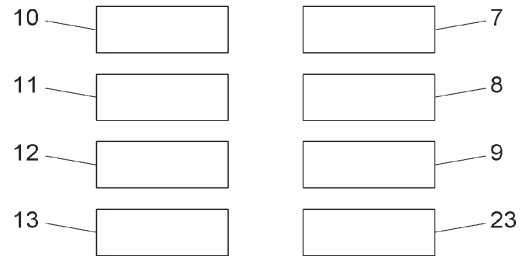

# Battery Charger Assembly

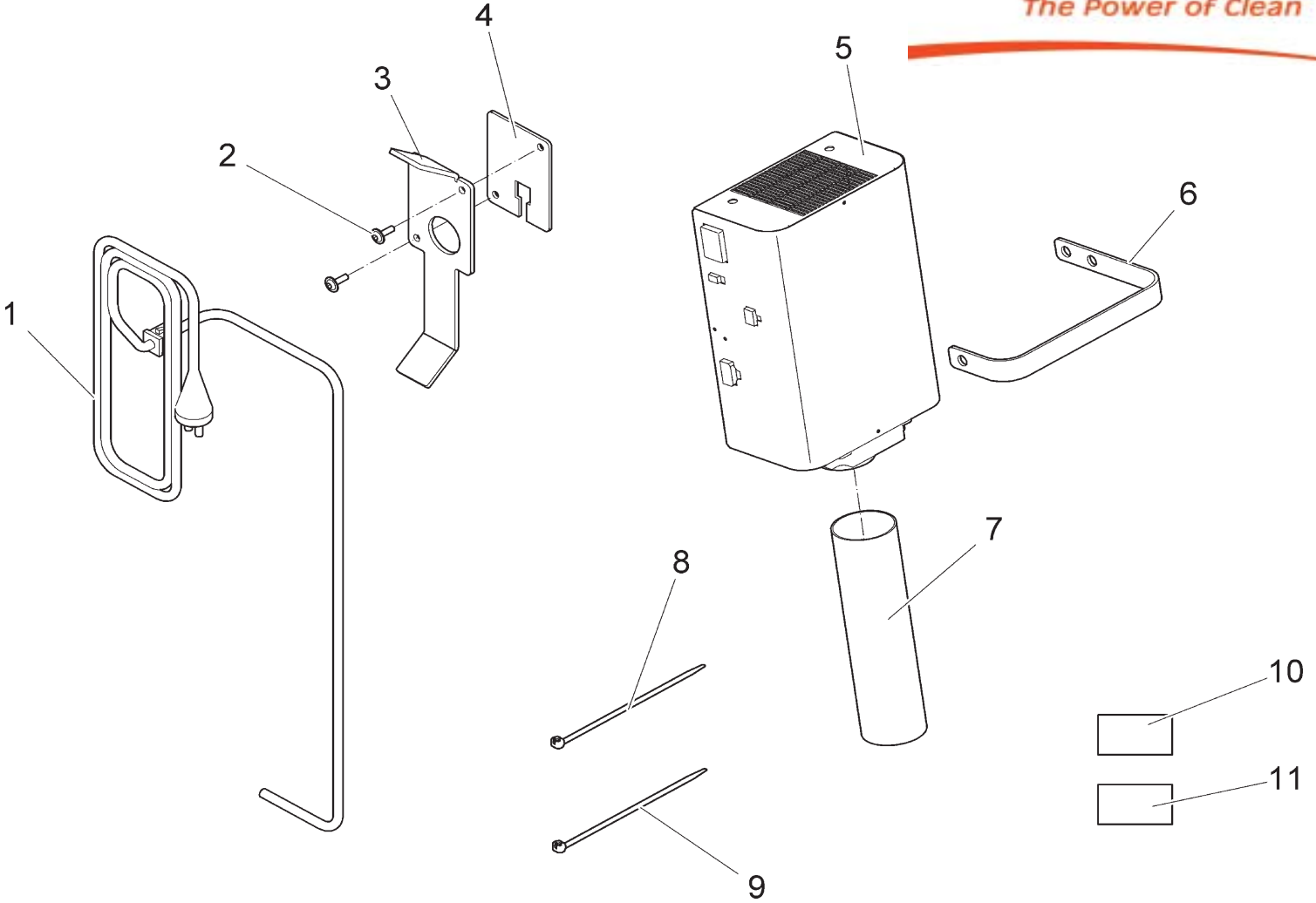

**Bill of Material - 99706218BT150**

Item	Spare part number	Mat. No.	Qty.	Description	Note
1	01079380	90532987	1	Power cable	
2	01017640	11177060	2	Lens flange screw	
3	01074240	90463746	2	Cap	
4	01079360	90533266	1	Covering	
5	01079370	96117197	1	On-board charger	
6	01077870	90517665	1	Tension band	
7	01078320	90512575	3	Hose	
8	00121150	90114810	8	Cable tie	
9	00967760	90156688	1	Cable tie	
10	03006770	97094304	1	Wire harness W6	
11	03006840	97094346	1	Wiring harness W8	
12	01079390	90533258	1	Cable retainer	

Attaches to Item 12 with Loctite!

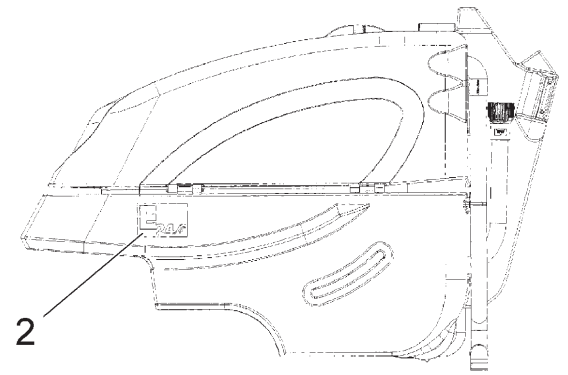
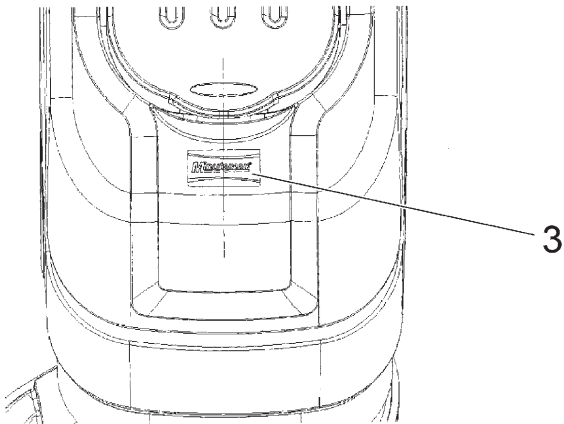
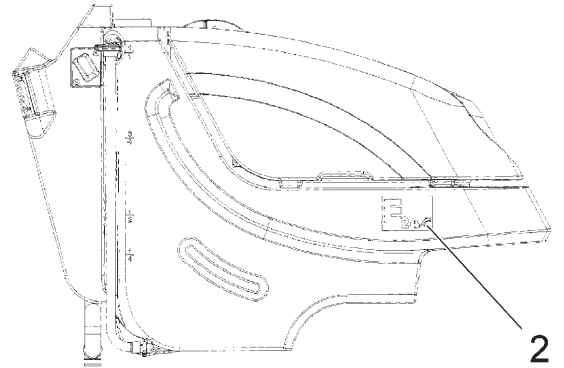
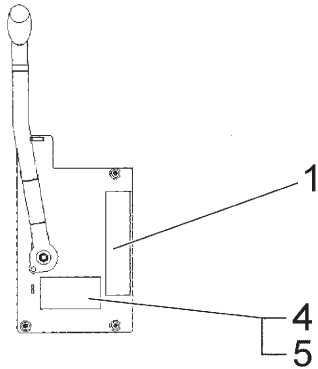

**Bill of Material - 99706218BT160**

Item	Spare part number	Mat. No.	Qty.	Description
1	01077440	17267212	1	Decal DETAILS
2	XXXXXXXX	17205261	2	Decal E33
3	03007820	17201145	1	Decal MINUTEMAN
4	XXXXXXXX	17212178	1	Type plate MINUTEMAN USA
5	00504370	13165014	2	Blind rivet

# Disc Scrub Deck Assembly I

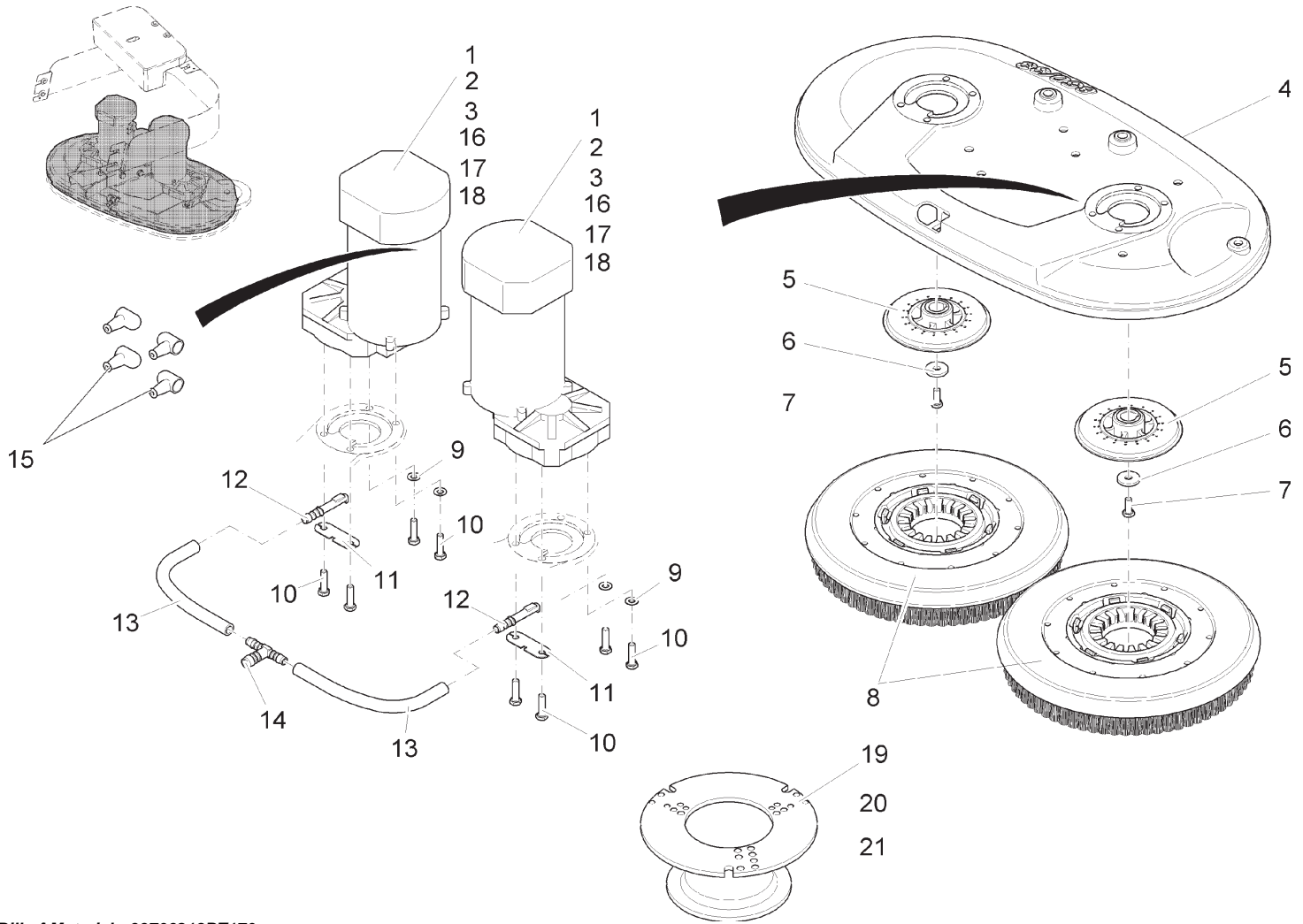

**Bill of Material - 99706218BT170**

Item	Spare part number	Mat. No.	Qty.	Description
1	01170220	90507484	2	Motor SCOTT 700W
2	01077230	01077230	2	Fitting key
3	01077240	01077240	1	Set (4pc.) Carbon brush
4	03008040	90501115	1	Housing
5	00512400	90324369	2	Carrier
6	00879170	90209537	2	Washer
7	00053090	11038213	2	Hexagon screw
8	99759900	99759900	2	Drive plate USA 430
9	00101550	12310264	4	Washer
10	00053110	11038254	8	Hexagon screw
11	01077750	90500216	2	Sheet metal
12	01078330	90500265	2	Spray tube
13	00180190	25842014	660mm	Hose
14	00901310	90275157	1	T-reducer muff
15	01078070	90524174	4	Protection cap
16	01077250	01077250	1	Spring
17	01077210	01077210	1	Gear
18	01077220	01077220	1	Circlip
19	00681500	90364365	1	Center-lock, lower part
20	00961490	11709011	6	Self tapping screw
21	00681490	90364373	1	Center-lock, upper part

# Disc Scrub Deck Assembly II

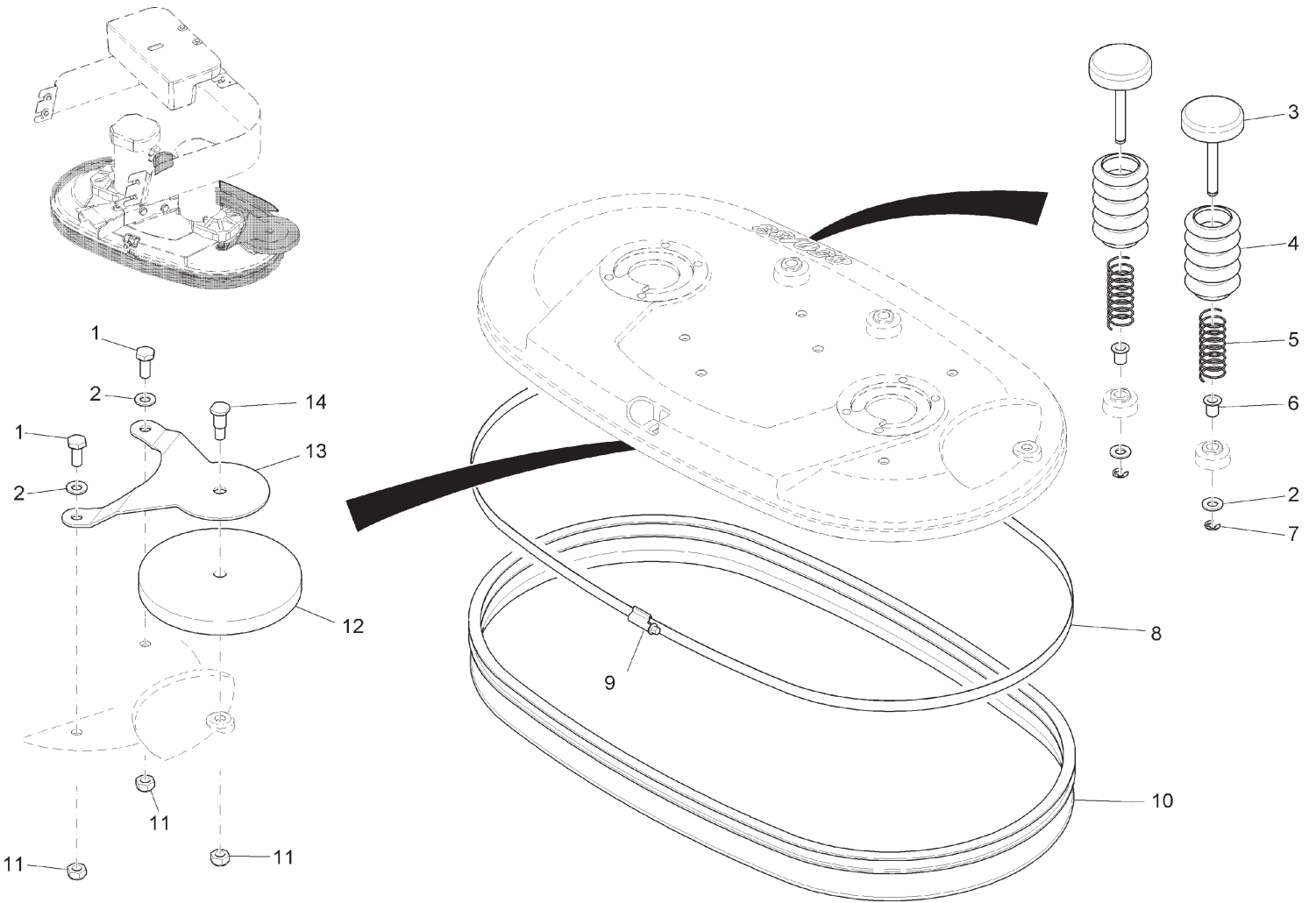

**Bill of Material - 99706218BT180**

Item	Spare part number	Mat. No.	Qty.	Description
1	00053310	11038346	2	Hexagon screw
2	00053760	12310058	2	Washer
3	01078000	96112388	2	Ejector
4	01078350	90500232	2	Bellow
5	01078340	90500208	2	Compression spring
6	01078360	14895437	2	Slide bearing bush
7	00046280	12640033	2	Thrust washer
8	00712300	17528548	2440 mm	Tension band
9	00901390	17528555	1	Tension band lock
10	01079970	90539800	1	Sealing strip
11	00051500	12040069	3	Hexagon nut
12	01170190	90501107	1	Deflector roller
13	01170180	90500638	1	Retainer
14	01077570	90507831	1	Screw

# Disc Scrub Deck Assembly III

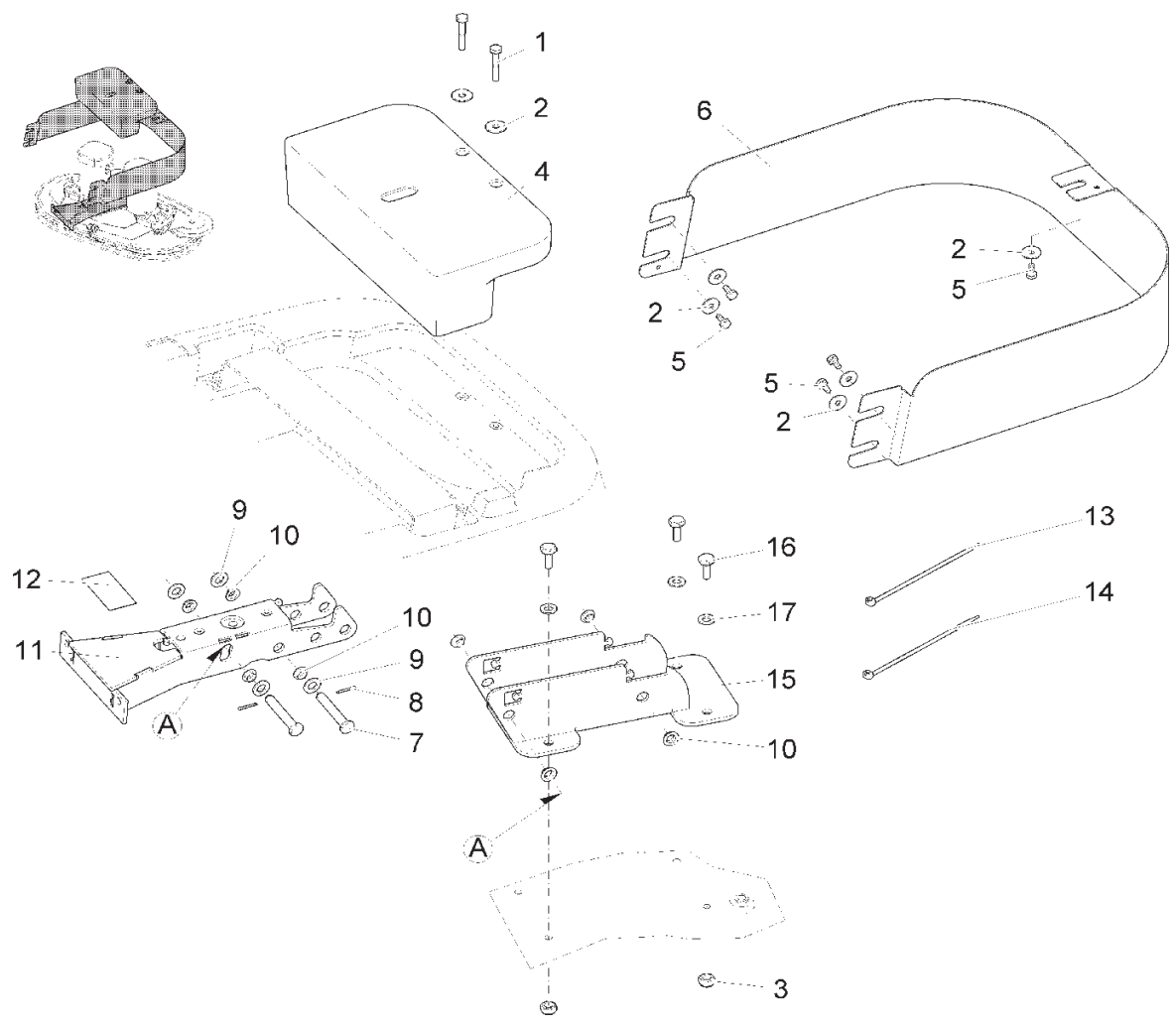

**Bill of Material - 99706218BT190**

Item	Spare part number	Mat. No.	Qty.	Description
1	00053120	11032208	2	Hexagon screw
2	00042900	12332029	7	Washer
3	00051500	12040069	2	Hexagon nut
4	03008090	96117205	1	Weight
5	00053080	11038197	5	Hexagon screw
6	01170210	90504390	1	Covering
7	00879650	13328414	2	Bolt
8	00553580	13280136	2	Cotter pin
9	00053770	12310066	4	Washer
10	01077510	14895478	8	Slide bearing bush
11	01170570	96115555	1	Rocker
12	01073530	17220013	1	Transparency
13	00121150	90114810	3	Cable tie
14	00967760	90156688	2	Cable tie
15	01170520	96110572	1	Retainer
16	00053310	11038346	2	Hexagon screw
17	00053760	12310058	2	Washer





**Revision F**  
**Effective November 1, 2008**  
**PowerBoss Made Simple Industrial Limited Warranty**

Minuteman International owner of PowerBoss warrants to the original purchaser/user that the product is free from defects in workmanship and materials under normal use. PowerBoss will, at its option, repair or replace without charge, parts that fail under normal use and service when operated and maintained in accordance with the applicable operation and instruction manuals. All warranty claims must be submitted through and approved by factory authorized repair stations.

This warranty does not apply to normal wear, or to items whose life is dependent on their use and care. Parts not manufactured by PowerBoss are covered by and subject to the warranties and/or guarantees of their manufacturers. Please contact Minuteman International for procedures in warranty claims against these manufacture.

**Special warning to purchaser** – Use of replacement parts not manufactured by PowerBoss or its designated licensees, will void all warranties expressed or implied. A potential health hazard exists without original equipment replacement.

All warranted items become the sole property of Minuteman International or PowerBoss or its original manufacturer, whichever the case may be.

PowerBoss disclaims any implied warranty, including the warranty of merchantability and the warranty of fitness for a particular purpose. PowerBoss assumes no responsibility for any special, incidental or consequential damages.

This limited warranty is applicable only in the U.S.A. and Canada, and is extended only to the original user/purchaser of this product. Customers outside the U.S.A. and Canada should contact their local distributor for export warranty policies. PowerBoss is not responsible for costs or repairs performed by persons other than those specifically authorized by PowerBoss. This warranty does not apply to damage from transportation, alterations by unauthorized persons, misuse or abuse of the equipment, use of non-compatible chemicals, or damage to property, or loss of income due to malfunctions of the product. If a difficulty develops with this machine, you should contact the dealer from whom it was purchased.

This warranty gives you specific legal rights, and you may have other rights, which vary from state to state. Some states do not allow the exclusion or limitation of special, incidental or consequential damages, or limitations on how long an implied warranty lasts, so the above exclusions and limitations may not apply to you.

	Travel*	Labor	Parts	Engine	Extended Warranty	Costs
<b>Walk behinds</b>						
Battery sweepers	Ninety days	One year	One year	N/A	2 years Parts + Labor (or 2000 Hours)	2%
IC sweepers	Ninety days	One year	One year	Through manufacturer	2 years Parts + Labor (or 2000 Hours)	2%
Battery scrubbers	Ninety days	Two years	Three years	N/A	3 Years Parts + Labor (or 3000 Hours)	2%
<b>Riders</b>						
Battery scrubbers	Ninety days	Two years	Three years/2000 hrs	N/A	3 Years Parts + Labor (or 3000 Hours)	2%
IC sweeper/scrubbers	Ninety days	Six months	Two years/2000 hrs	Two years/3000 hrs**	2 years Parts + Labor (or 2000 Hours)	3%
IC sweepers	Ninety days	Six months	Four years/3000 hrs	Five years/3000 hrs**	4 Years Parts + 2 Years Labor (or 4000 Hours)	3%
<b>Exceptions</b>						
Apex series sweeper	Ninety days	One year	One year/1000 hrs	One year/1000 hrs**	2 years Parts + Labor (or 2000 Hours)	3%
6X sweeper	Ninety days	Six months	Two years/2000 hrs	Two years/2000 hours**	2 years Parts + Labor (or 2000 Hours)	3%

**Tank Bladders** Eight years/ no additional labor  
**Polypropylene plastic tanks** Ten years/ no additional labor  
**Batteries** 0-3 months full replacement, 4-12 prorated credit  
**Charges** One-year replacement  
**Replacement parts** Ninety days

\*Two-hour cap

\*\*Through engine manufacture. See section 3 of warranty manual for engine warranty exceptions

\*\*\*Base upon dealer's certification status

**Extended Warranty MUST be signed up within 30 days of delivery to End User (Dealer has 1 Year from Receiving Machine to Sign up extended Warranty)**

**Extended Warranty Cost is based on Invoice Price multiplied by the Percentage listed in the Extended Warranty Column**

All above labor and travel reimbursed at 65 or 75% of the published shop rate.

Power boss, Inc.  
 175 Anderson Street  
 Aberdeen, NC 28315  
 Phone: (910) 944-2105 Fax: (910) 944-7409  
**A Member of the Hako Group**

**988033PB**  
**Rev \* 08/09**